

- Clip-on bracket for 2109, 2132, 3732 and 3832 series slides
- Bottom and platform mounting options
- HAB - 96 hours salt spray test
- HAZ - 12 hours salt spray test

- Équerres clipsables pour glissières série 2109, 2132, 3732 et 3832
- Options de montage sous tiroir/plateau
- HAB - 96 heures de tenue au brouillard salin
- HAZ - 12 heures de tenue au brouillard salin

- Aufsteckwinkel für Schienen der Baureihe 2109, 2132, 3732 & 3832
- Optionen für Boden-/Plattformmontage
- HAB - 96 Stunden Salzsprühtest
- HAZ - 12 Stunden Salzsprühtest

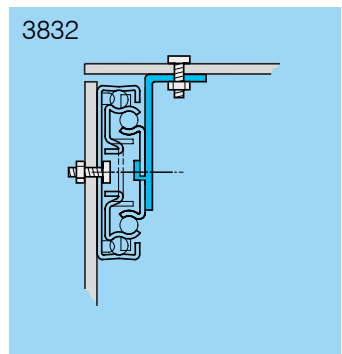
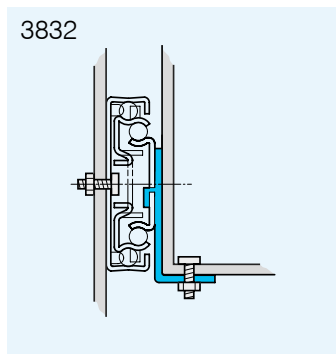
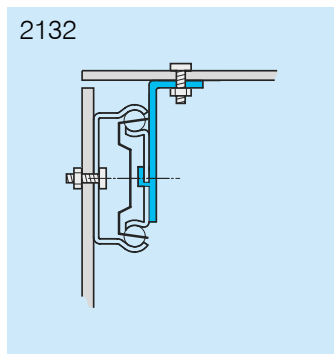
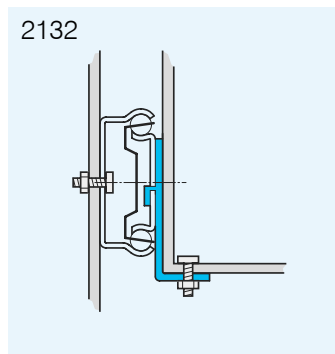
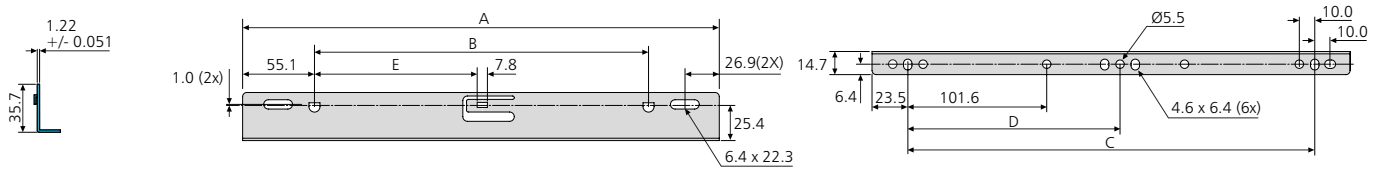
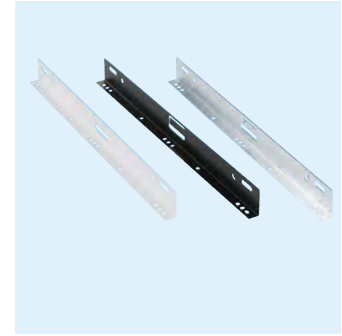

633xx	mm						kg
	Slide/Glissières/Schienen						
	A	B	C	D	E	W	
*63335-2	3732/3832-35	346.7	236.5	300.0	150.0	114.4	0.32
*63340-2	3732/3832-40 2132-40 2109-40	396.7	286.6	350.0	175.0	139.4	0.36
*63345-2	3732/3832-45 2132-45/60/65/70 2109-45	446.8	336.6	400.0	200.0	164.4	0.41
*63350-2	3732/3832-50 2132-50 2109-50	496.8	386.6	450.0	225.0	189.4	0.46
*63355-2	3732/3832-55/60/65/70 2132-55 2109-55	546.8	436.6	500.0	250.0	214.4	0.51

* Prefix HAZ for zinc plate, HAB for black zinc plate, HAW for white electro-plate
 Préfixe HAZ pour zingué brillant, HAB pour zingué noir, HAW pour laqué blanc
 Präfix HAZ für helle Oberfläche/ HAB für schwarze Oberfläche/ HAW für weiße Oberfläche

Notes:

- Fixing recommendation: M4 screw/ 4mm wood screw
- Not 3832TR/HDTR/EC
- Please refer to 2D CAD drawings for dimensional tolerances

Notes:

- Visserie recommandée: Vis M4/vis à bois 4mm
- Sauf 3832TR/HDTR/EC
- Pour les tolérances dimensionnelles, veuillez vous reporter à nos plans 2D

Hinweise:

- Empfohlene Befestigung: Schraube M4/ Holzschraube 4mm
- Nicht 3832TR/HDTR/EC
- Bitte beachten Sie die 2D-CAD-Zeichnung wegen Abmessungstoleranzen