

Metallbalgkupplung MKK-S mit Klemmkonus

Metal bellow coupling MKK-S with clamping cone

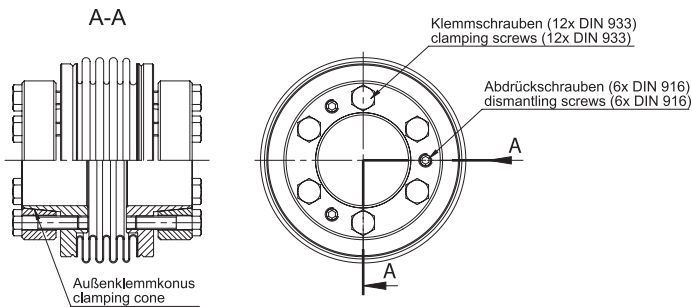

Merkmale

- Kleines Massenträgheitsmoment
- Kurze Einbaulänge
- Wartungsfrei
- Ausgewuchtet
- Spielfrei
- Ausgleich von Fluchtungsfehlern

Werkstoff der Naben: Stahl
 Werkstoff des Metallbalges: Edelstahl
 Verbindung Balg-Nabe: geschweißt

Bestellbezeichnung / Beispiel:

MKK-S-40 - 20H7 - 22H7
 Typ+Größe Bohrung D1 Bohrung D2

Characteristics

- Very mass moment of inertia torque
- Short installation length
- Maintenance-free
- Balanced
- Backlash-free torque transmission
- Compensation of alignment mistakes

Material of hubs: Steel
 Material of bellows: Stainless steel
 Connection of bellows to hub: Welded

Order description / example:

MKK-S-40 - 20H7 - 22H7
 Type+Size Bore D1 Bore D2

Standard Optionen / Standardized options



Gewünschte Optionen müssen im Bestelltext angegeben werden (Legende Symbole S. 7).
 Desired options have to be mentioned in the order text (key symbols p. 7).

MKK-S-15	15 [Nm]	Nennmoment Nominal torque	40 [Nm]	MKK-S-40
	8.5 [10 ³ Nm/rad]	Torsionssteife Torsional stiffness	26.5 [10 ³ Nm/rad]	
	87 [N/mm]	Laterale Federsteife Lateral spring stiffness	175 [N/mm]	
	13 [N/mm]	Axiale Federsteife Axial spring stiffness	27.5 [N/mm]	
	±0.2 [mm]	Max. lateraler Wellenversatz Max. lateral shaft misalignment	±0.2 [mm]	
	±1.0 [mm]	Max. axialer Wellenversatz Max. axial shaft misalignment	±1.0 [mm]	
	±1 [Grad] [Degree]	Max. angularer Wellenversatz Max. angular shaft misalignment	±1 [Grad] [Degree]	
	0.18 [10 ⁻³ kgm ²]	Trägheitsmoment Inertia torque	0.36 [10 ⁻³ kgm ²]	
	0.50 [kg]	Masse Mass	0.80 [kg]	
	M5 [DIN 933-10.9]	Klemmschrauben Clamping screws	M5 [DIN 933-10.9]	
	7 M _A [Nm]	Anzugsmoment der Schrauben Tightening torque of screws	7 M _A [Nm]	

MKK-S-60

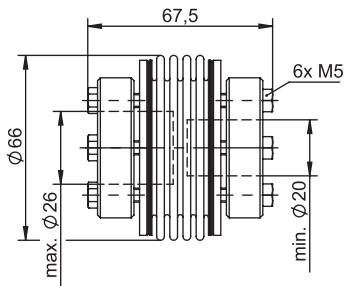

60 [Nm]	Nennmoment Nominal torque	100 [Nm]
33.5 [10 ³ Nm/rad]	Torsionssteife Torsional stiffness	65 [10 ³ Nm/rad]
262 [N/mm]	Laterale Federsteife Lateral spring stiffness	225 [N/mm]
49 [N/mm]	Axiale Federsteife Axial spring stiffness	35 [N/mm]
±0.2 [mm]	Max. lateraler Wellenversatz Max. lateral shaft misalignment	±0.22 [mm]
±1.0 [mm]	Max. axialer Wellenversatz Max. axial shaft misalignment	±1.3 [mm]
±1 [Grad]	Max. angularer Wellenversatz Max. angular shaft misalignment	±1 [Grad]
0.37 [10 ⁻³ kgm ²]	Trägheitsmoment Inertia torque	1.34 [10 ⁻³ kgm ²]
0.83 [kg]	Masse Mass	1.46 [kg]
M5 [DIN 933-10.9]	Klemmschrauben Clamping screws	M6 [DIN 933-10.9]
7 M _A [Nm]	Anzugsmoment der Schrauben Tightening torque of screws	12 M _A [Nm]

MKK-S-100

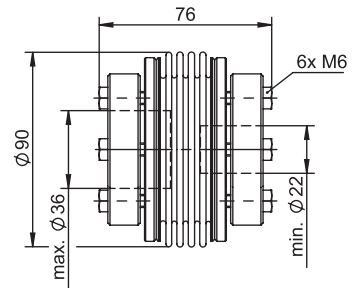

MKK-S-150

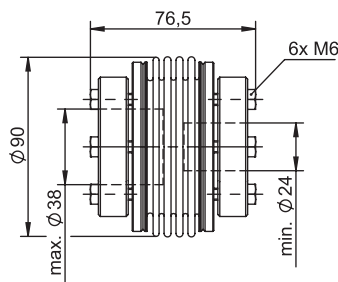

150 [Nm]	Nennmoment Nominal torque	200 [Nm]
80 [10 ³ Nm/rad]	Torsionssteife Torsional stiffness	110 [10 ³ Nm/rad]
357 [N/mm]	Laterale Federsteife Lateral spring stiffness	502 [N/mm]
78.5 [N/mm]	Axiale Federsteife Axial spring stiffness	78.5 [N/mm]
±0.22 [mm]	Max. lateraler Wellenversatz Max. lateral shaft misalignment	±0.20 [mm]
±1.25 [mm]	Max. axialer Wellenversatz Max. axial shaft misalignment	±1.25 [mm]
±1 [Grad]	Max. angularer Wellenversatz Max. angular shaft misalignment	±1 [Grad]
1.39 [10 ⁻³ kgm ²]	Trägheitsmoment Inertia torque	3.00 [10 ⁻³ kgm ²]
1.46 [kg]	Masse Mass	2.50 [kg]
M6 [DIN 933-10.9]	Klemmschrauben Clamping screws	M6 [DIN 933-10.9]
12 M _A [Nm]	Anzugsmoment der Schrauben Tightening torque of screws	12 M _A [Nm]

MKK-S-200

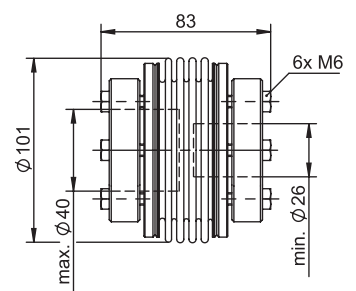

MKK-S-350

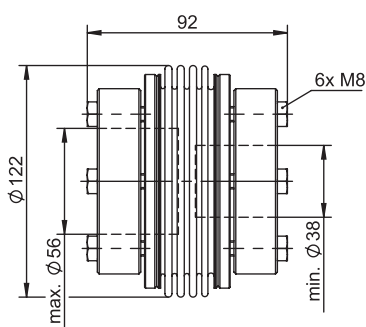

350 [Nm]	Nennmoment Nominal torque	500 [Nm]
160 [10 ³ Nm/rad]	Torsionssteife Torsional stiffness	190 [10 ³ Nm/rad]
611 [N/mm]	Laterale Federsteife Lateral spring stiffness	765 [N/mm]
60 [N/mm]	Axiale Federsteife Axial spring stiffness	80 [N/mm]
±0.20 [mm]	Max. lateraler Wellenversatz Max. lateral shaft misalignment	±0.17 [mm]
±1.5 [mm]	Max. axialer Wellenversatz Max. axial shaft misalignment	±1.3 [mm]
±1 [Grad]	Max. angularer Wellenversatz Max. angular shaft misalignment	±1 [Grad]
6.20 [10 ⁻³ kgm ²]	Trägheitsmoment Inertia torque	6.40 [10 ⁻³ kgm ²]
3.60 [kg]	Masse Mass	3.60 [kg]
M8 [DIN 933-10.9]	Klemmschrauben Clamping screws	M8 [DIN 933-10.9]
30 M _A [Nm]	Anzugsmoment der Schrauben Tightening torque of screws	30 M _A [Nm]

MKK-S-500

