

ROLLON®
BY TIMKEN

Compact Rail



Roller guide in hardened rails



HA-CO has been Rollon's official distribution partner for decades and is therefore your competent partner in the field of linear technology. We have standard products in stock and special solutions to suit your application are realized in our production - flexible - fast - HA-CO

Product explanation



> Self-aligning linear guides with bearings and C-profile featuring newly designed robust steel slider



Fig. 84

Compact Rail is the product family of guide rails consisting of roller sliders with radial bearings which slide on the internal, induction hardened and ground raceways of a C-profile made from cold-drawn roller bearing carbon steel.

Compact Rail consists of three product series: the fixed bearing rail, the compensating bearing rail and the floating bearing rail. They can be combined to create self-aligning systems to compensate misalignment errors on two planes: axially up to 3.9 mm and radially up to 2°. All products are available in zinc plating, with other treatments for higher corrosion resistance as an option. There are five different sizes of guide rails and many different versions and lengths of the slide bearings, depending on the size and load requirement.

The most important characteristics:

- Compact size
- Corrosion resistant surface
- Not sensitive to dirt due to internal raceways and large rollers
- Hardened and ground raceways
- Self-aligning in two planes
- Quieter than recirculating ball systems
- High operating speeds
- Wide temperature range
- Easy adjustment of slider in the guide rail
- Different anticorrosion treatments available for rails and slider bodies

Preferred areas of application:

- Cutting machines
- Medical equipment
- Packaging machines
- Photographic lighting equipment
- Construction and machine technology (doors, protective covers)
- Robots and manipulators
- Automation
- Handling
- Special vehicles

Fixed bearing rails F-rail (Rollon T-rails)

Fixed bearing rails are used as the main load bearing of radial and axial forces.



Fig. 85

Floating bearing rails L-rail (Rollon U-rails)

The floating bearing rails are used for load bearing of radial forces and, in combination with the fixed bearing F-rail or compensation K-rail, as a support bearing for occurring moment loads.



Fig. 86

Compensation bearing rails (K-rails)

The compensation bearing rails are used for the load bearing of radial and axial forces. Tolerance compensation in two planes can be implemented in combination with the U-rail.



Fig. 87

Self-aligning system: F+L

The combination of fixed bearing rail and floating bearing rail allows for deviations in parallelism.



Fig. 88

Self-aligning system: K+L

The combination of compensation rail and floating bearing rail allows for deviations in parallelism and height offset.



Fig. 89

RFO/RLO/RKO-slider (Rollon NSW/NSA)

Robust zinc plated steel slider with roller bearings, self-centering heads with wipers, longitudinal seals to protect the internal components and a top sealing strip to prevent accidental tampering of the fixed rollers. The slider body is accurately finished with matte longitudinal edge chamfer and a shining ground flat surface. It is available for all sizes, configurable with up to six rollers depending on the load requirement.



Fig. 90

RFS/RLS/RKS/ROS-slider (Rollon CS)

Constructed with zinc-plated steel body and sturdy wipers (optional) made of polyamide. Available for all sizes. Depending on the load requirement, slider is configurable with up to six rollers.



Fig. 91

RFP/RLP/RKP-slider (Rollon NSD/NSDA)

Constructed as the NSW/NSA-slider with mounting holes parallel to the direction of preferred loading. It is available for sizes 28 and 43, with three or five rollers, depending on load case and load direction set with the corresponding configuration.



Fig. 92

Rollers

Also available individually in all sizes. Available as eccentric or concentric rollers. Optionally available with splash-proof plastic seal (2RS) or with steel cover disc (2Z).



Fig. 93

Wipers

The slider heads are equipped with special slow release felt pads and are free to rotate with respect to the slider body, so that the felts are always in contact with the raceways to ensure a perfect lubrication. The felts can be grased through a dedicated oil refilling access on the front of the head, simply by means of a syringe oiler.



Fig. 94

Alignment fixture

The alignment fixture AT / AK is used during installation of joined rails in order to precisely align the rails with each other.



Fig. 95

Technical data

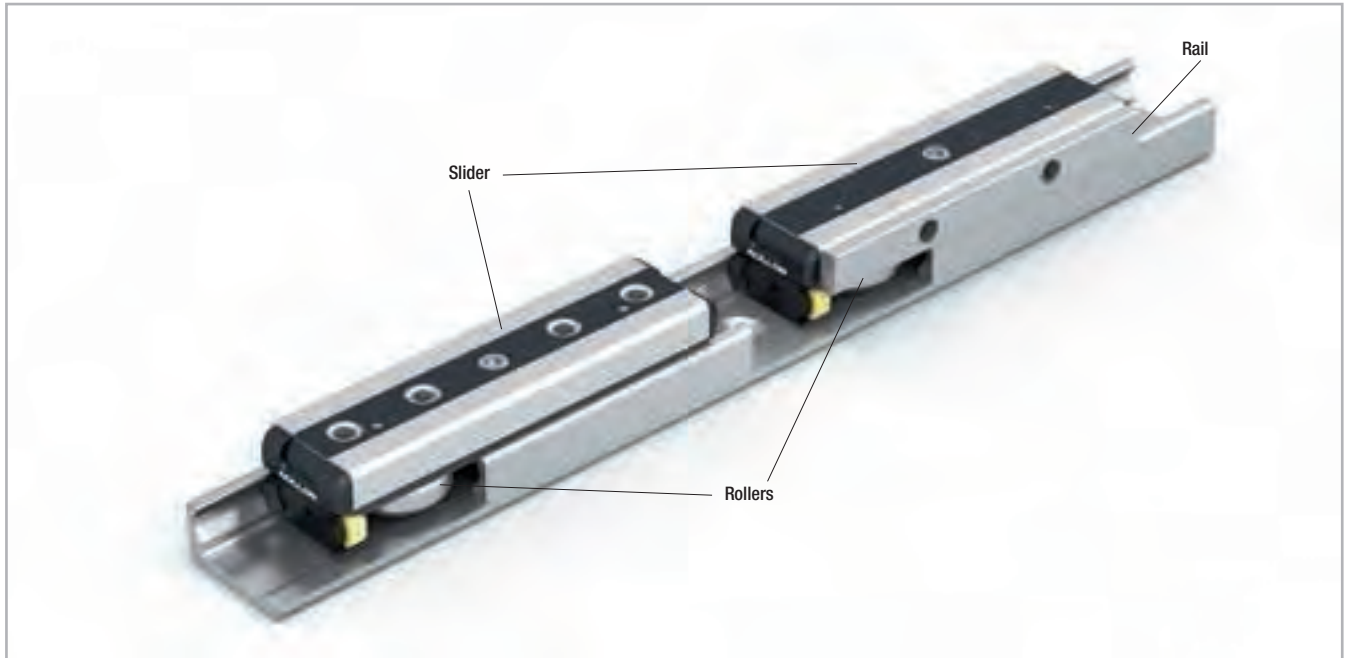

Fig. 96

Performance characteristics:

- Available sizes for F-rail, L-rail: 18, 28, 35, 43, 63
- Available sizes for K-rail: 43, 63
- Max. operating speed: 9 m/s (354 in/s)
(depending on application)
- Max. acceleration: 20 m/s² (787 in/s²)
(depending on application)
- Max. radial load capacity: 15,000 N (per slider)
- Temperature range: -20 °C to +120 °C (-4 °F to +248 °F)
briefly up to max. +150 °C (+302 °F)
- Available rail lengths from 160 mm to 3,600 mm (6.3 in to 142 in) in
80-mm increments (3.15 in), longer single rails up to max. 4,080
mm (160.6 in) on request
- Roller pins lubricated for life
- Roller seal/shield: standard 2Z (steel cover disk), 2RS (splash-proof)
- Rollers material: steel 100Cr6 (also available stainless steel AISI
440)
- Rail raceways are induction hardened and ground
- Rails and slider bodies are standard zinc-plated according to
ISO 2081
- Rail material of F- and L-rails in sizes 18: cold-drawn roller bearing
carbon steel C43 F
- Rail material of K-rails, as well as F- and L-rails in size 28 to 63:
Cf53

Notes:

- The sliders are equipped with rollers that are in alternating contact
with both sides of the raceway. Markings on the body around the roller
pins indicate correct arrangement of the rollers to the external load
- With a simple adjustment of the eccentric rollers, the desired clear-
ance or preload on the rail and slider can be set.
- Rails in joined design are available for longer transverse distances
(see pg. CR-96)
- The K rails are not suitable for vertical installation
- Screws of property class 10.9 must be used
- Differences in screw sizes must be observed
- When mounting the rails, it is crucial to ensure that the mounting
holes in the structure are properly chamfered. (see pg. CR-89, tab. 73)
- The general illustrations show NSW-sliders as an example
- Rollers are available also in stainless steel version (see pg. CR-72).

> Configurations and behavior of the slider under yawing moment M_z

Individual slider under M_z moment load

When an overhanging load in an application with a single slider per rail causes an M_z moment in one direction, a 4 to 6 roller Compact Rail slider is available. These sliders are available in both configuration A and B in regards to the roller arrangement to counter the acting M_z moment load. The moment capacity of these sliders in the M_z -direction varies significantly through spacing L_1 and L_2 in accordance with the direction of rotation of M_z . Especially in the use of two parallel rails, for example with a F+L-system,

it is extremely important to pay attention to the correct combination of the slider configuration A and B, in order to use the maximum load capacities of the slider.

The diagrams below illustrate this concept of the A and B configuration for sliders with 4 and 6 rollers. The maximum allowable M_z -moment is identical in both directions for all 3 and 5 roller sliders.

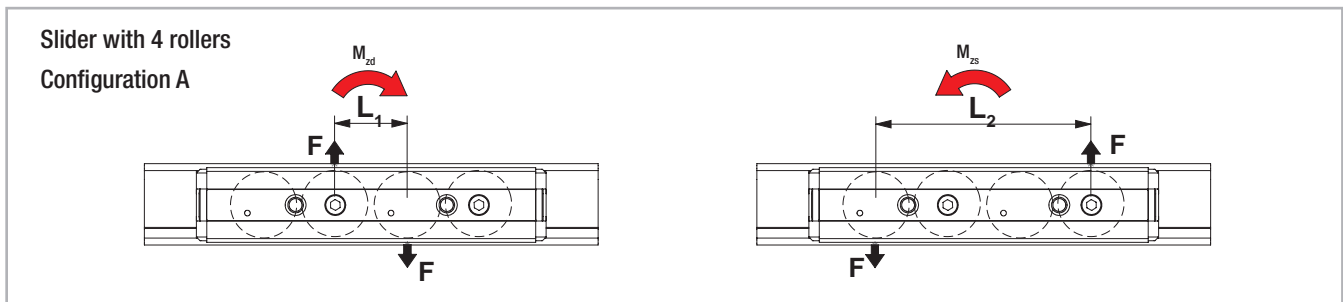

Fig. 97

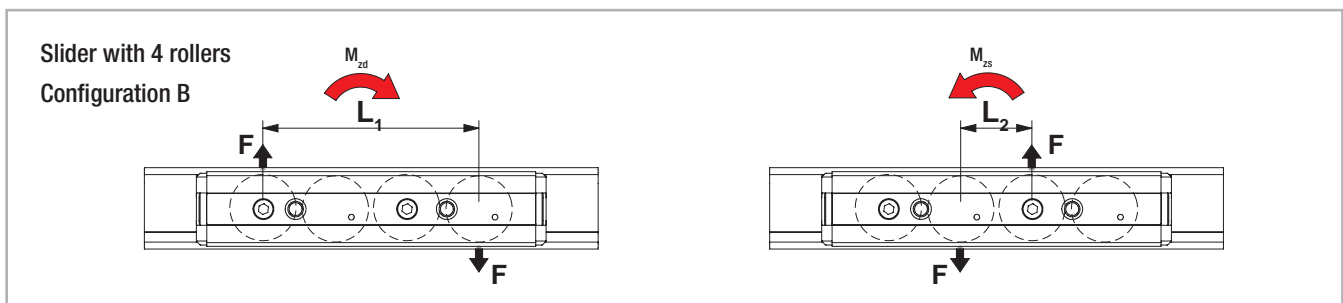

Fig. 98

Two sliders under M_z moment load

When an overhanging load acts on an application with two sliders per rail and causes an M_z -moment in one direction, different support reactions occur on the two sliders. For this reason, an optimal arrangement of slider configurations must be achieved to reach the maximum load capacities. In practice, when using NSW-sliders with 3 or 5 rollers, the two sliders must be installed rotated by 180° so that the slider is always loaded on the side with the highest number of rollers (with

NSA sliders this is not possible due to different rail geometries).

For an even number of rollers this has no effect. The NSD-sliders with installation option from above or below cannot be installed due to the position of the rollers in reference to the installation side, therefore they are available in the configurations A and B (see fig. 100).

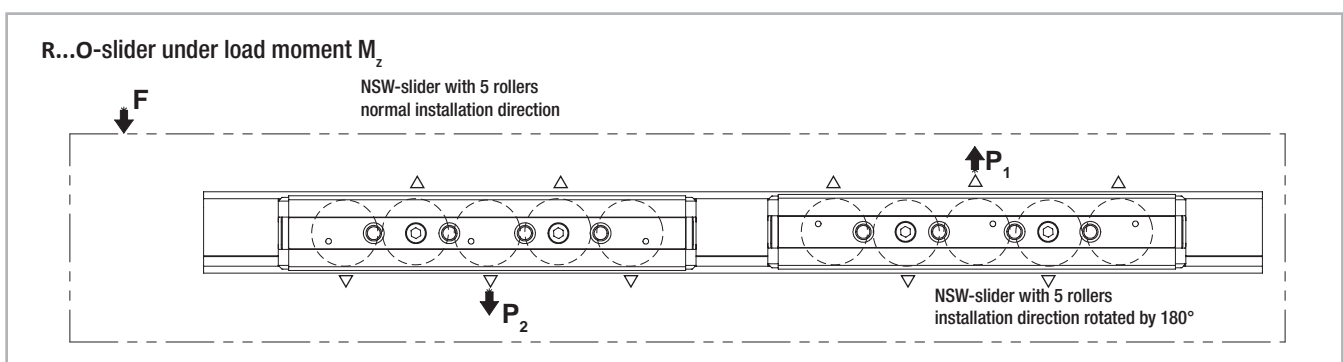

Fig. 99

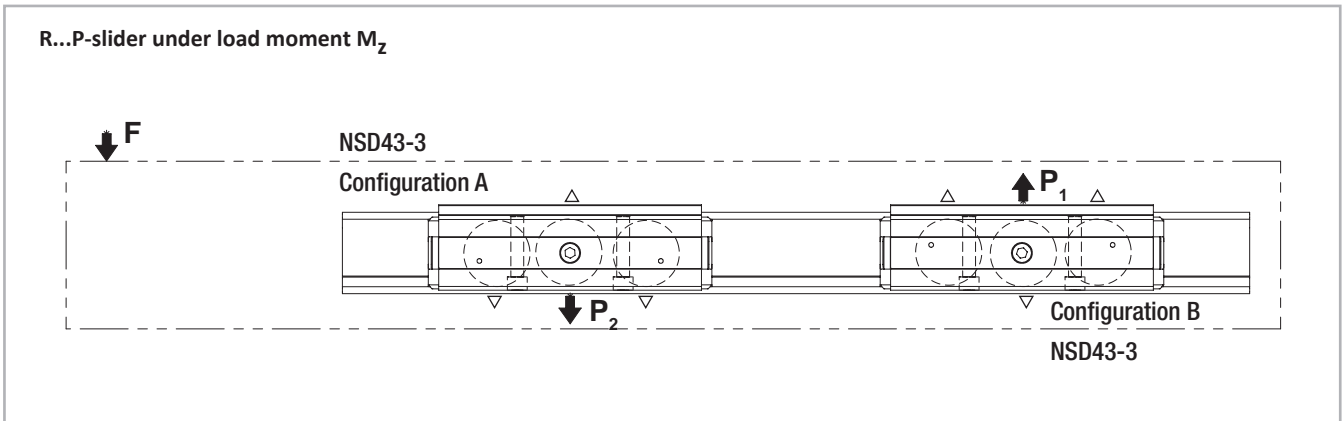

Fig. 100

Slider configurations for various load cases

Arrangement DS

This is the recommended arrangement for use of two sliders under M_z -moment when using one rail. Also see previous page: Two sliders under M_z moment load.

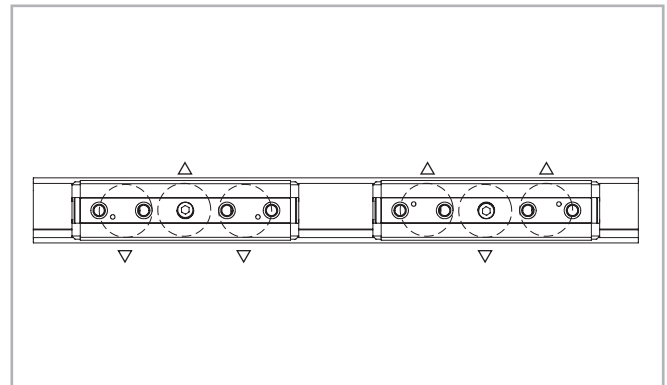

Fig. 101

Arrangement DD

When using a pair of guide rails with two sliders each under M_z moment load, the second system should be designed in arrangement DD. This results in the following combination: one guide rail with two sliders in arrangement DS and the other guide rail with 2 sliders in arrangement DD. This allows even load and moment distribution between the two parallel rails.

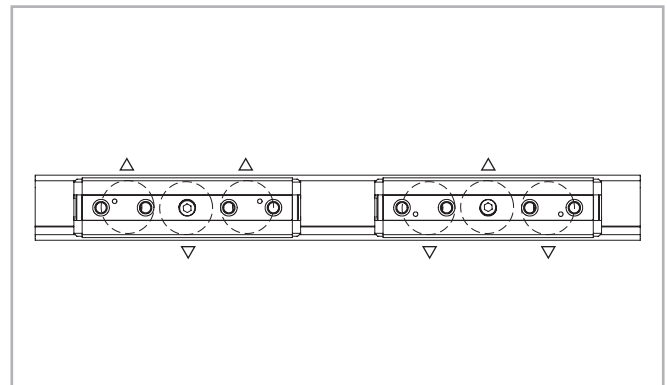

Fig. 102

Arrangement DA

Standard arrangement if no other information is given. This arrangement is recommended if the load point is located within the two outside points of the sliders.

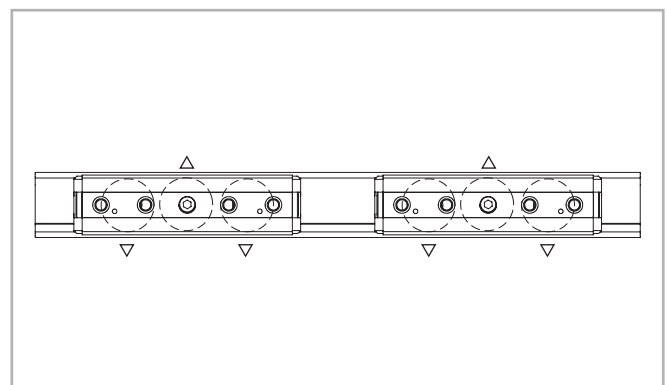

Fig. 103

> Load capacities

Slider

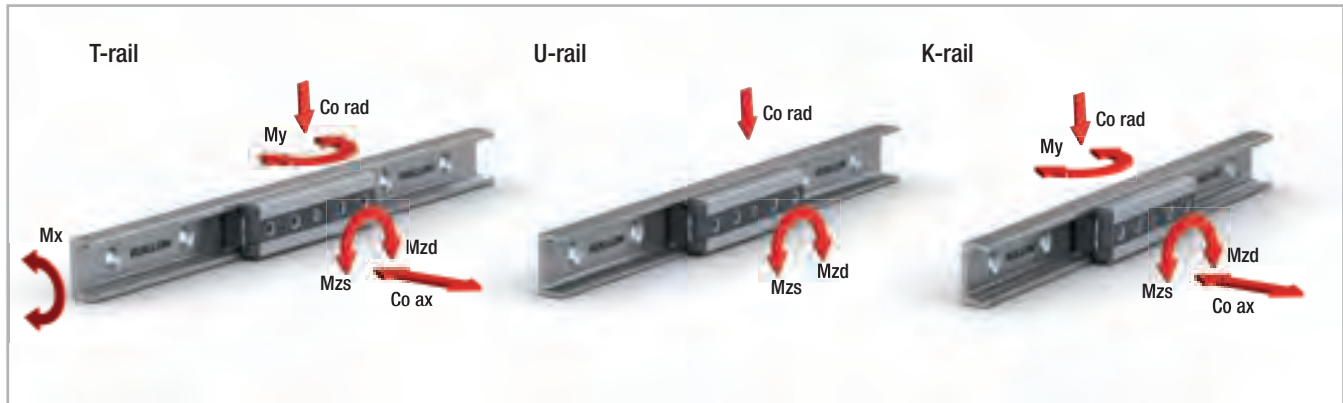

Fig. 104

The load capacities in the following tables each apply for one slider.
When using the slider in U-rails (floating bearing rails) the values are

$C_{0ax} = 0$, $M_x = 0$ and $M_y = 0$. When using the sliders in K-rails (compensation rails) the value is: $M_x = 0$.

Load capacities R...O / R...P

Type	No. of rollers	Load capacities and moments							Weight [kg]
		C [N]	C_{0rad} [N]	C_{0ax} [N]	M_x [Nm]	M_y [Nm]	M_z [Nm]		
							M_{zd}	M_{zs}	
RFO/RLO18-3 -...	3	1530	820	260	1.5	4.7	8.2	8.2	0.096
RFO/RLO18-4A -...	4	1530	820	300	2.8	7	8.2	24.7	0.096
RFO/RLO18-4B -...	4	1530	820	300	2.8	7	24.7	8.2	0.11
RFO/RLO18-5 -...	5	1830	975	360	2.8	9.4	24.7	24.7	0.11
RFO/RLO18-6A -...	6	1830	975	440	3.3	11.8	24.7	41.1	0.138
RFO/RLO18-6B -...	6	1830	975	440	3.3	11.8	41.1	24.7	0.138
RFO/RLO28-3 -...	3	4260	2170	640	6.2	16	27.2	27.2	0.23
RFO/RLO28-4A -...	4	4260	2170	750	11.5	21.7	27.2	81.7	0.29
RFO/RLO28-4B -...	4	4260	2170	750	11.5	21.7	81.7	27.2	0.29
RFO/RLO28-5 -...	5	5065	2580	900	11.5	29	81.7	81.7	0.35
RFO/RLO28-6A -...	6	5065	2580	1070	13.7	36.2	81.7	136.1	0.42
RFO/RLO28-6B -...	6	5065	2580	1070	13.7	36.2	136.1	81.7	0.42
RFO/RLO28L-3-...	3	4260	2170	640	6.2	29	54.4	54.4	0.141
RFO/RLO28L-4A-...	4	4260	2170	750	11.5	29	54.4	108.5	0.164
RFO/RLO28L-4B-...	4	4260	2170	750	11.5	29	108.5	54.4	0.164
RFO/RLO28L-4C-...	4	4260	2170	750	11.5	29	81.7	81.7	0.164
RFO/RLO28L-5A-...	5	5065	2580	900	11.5	29	81.7	81.7	0.185
RFO/RLO28L-5B-...	5	6816	3472	640	6.2	29	54.4	54.4	0.185
RFP/RLP28-3A -...	3	4260	2170	640	6.2	16	27.2	27.2	0.23
RFP/RLP28-3B -...	3	4260	2170	640	6.2	16	27.2	27.2	0.23
RFP/RLP28-5A -...	5	5065	2580	900	11.5	29	81.7	81.7	0.35
RFP/RLP28-5B -...	5	5065	2580	900	11.5	29	81.7	81.7	0.35

Tab. 35

Type	No. of rollers	Load capacities and moments							Weight [kg]
		C [N]	C _{Orad} [N]	C _{Oax} [N]	M _x [Nm]	M _y [Nm]	M _z [Nm]		
							M _{zd}	M _{zs}	
RFO/RLO35-3 -...	3	8040	3510	1060	12.9	33.7	61.5	61.5	0.44
RFO/RLO35-4A -...	4	8040	3510	1220	23.9	43.3	52.7	158.1	0.53
RFO/RLO35-4B -...	4	8040	3510	1220	23.9	43.3	158.1	52.7	0.53
RFO/RLO35-5 -...	5	9565	4180	1460	23.9	57.7	158.1	158.1	0.64
RFO/RLO35-6A -...	6	9565	4180	1780	28.5	72.2	158.1	263.4	0.76
RFO/RLO35-6B -...	6	9565	4180	1780	28.5	72.2	263.4	158.1	0.76
RFP/RLP35-3A -...	3	8040	3510	1060	12.9	33.7	61.5	61.5	0.44
RFP/RLP35-3B -...	3	8040	3510	1060	12.9	33.7	61.5	61.5	0.44
RFP/RLP35-5A -...	5	9565	4180	1460	23.9	57.7	158.1	158.1	0.64
RFP/RLP35-5B -...	5	9565	4180	1460	23.9	57.7	158.1	158.1	0.64
RFO/RLO43-3 -...	3	12280	5500	1570	23.6	60	104.5	104.5	0.8
RFO/RLO43-4A -...	4	12280	5500	1855	43.6	81.5	104.5	313.5	1.02
RFO/RLO43-4B -...	4	12280	5500	1855	43.6	81.5	313.5	104.5	1.02
RFO/RLO43-5 -...	5	14675	6540	2215	43.6	108.6	313.5	313.5	1.24
RFO/RLO43-6A -...	6	14675	6540	2645	52	135.8	313.5	522.5	1.47
RFO/RLO43-6B -...	6	14675	6540	2645	52	135.8	522.5	313.5	1.47
RFO/RLO43L-3-...	3	12280	5500	1570	23.6	108.6	209	209	0.45
RFO/RLO43L-4A-...	4	12280	5500	1855	43.6	108.6	209	418	0.52
RFO/RLO43L-4B-...	4	12280	5500	1855	43.6	108.6	418	209	0.52
RFO/RLO43L-4C-...	4	12280	5500	1855	43.6	108.6	313.5	313.5	0.52
RFO/RLO43L-5A-...	5	14675	6540	2215	43.6	108.6	313.5	313.5	0.59
RFO/RLO43L-5B-...	5	19650	8800	1570	23.6	108.6	209	209	0.59
RKO43-3 -...	3	12280	5100	1320	0	50.4	96.9	96.9	0.8
RKO43-4A -...	4	12280	5100	1320	0	54.3	96.9	290.7	1.02
RKO43-4B -...	4	12280	5100	1320	0	54.3	290.7	96.9	1.02
RKO43-5 -...	5	14675	6065	1570	0	108.7	290.7	290.7	1.24
RKO43-6A -...	6	14675	6065	1570	0	108.7	290.7	484.5	1.47
RKO43-6B -...	6	14675	6065	1570	0	108.7	484.5	290.7	1.47
RKO43L-3-...	3	12280	5100	1320	0	97.7	188.7	188.7	0.45
RKO43L-4A-...	4	12280	5100	1320	0	97.7	188.7	377.3	0.52
RKO43L-4B-...	4	12280	5100	1320	0	97.7	377.3	188.7	0.52
RKO43L-4C-...	4	12280	5100	1320	0	97.7	283	283	0.52
RKO43L-5A-...	5	14675	6065	1570	0	97.7	283	283	0.59
RKO43L-5B-...	5	19650	8160	1820	0	97.7	188.7	188.7	0.59
RFP/RLP43-3A -...	3	12280	5500	1570	23.6	60	104.5	104.5	0.8
RFP/RLP43-3B -...	3	12280	5500	1570	23.6	60	104.5	104.5	0.8
RFP/RLP43-5A -...	5	14675	9540	2215	43.6	108.6	313.5	313.5	1.24
RFP/RLP43-5B -...	5	14675	9540	2215	43.6	108.6	313.5	313.5	1.24
RKP43-3A -...	3	12280	5100	1320	0	50.4	96.9	96.9	0.8
RKP43-3B -...	3	12280	5100	1320	0	50.4	96.9	96.9	0.8
RKP43-5A -...	5	14675	6065	1570	0	108.7	290.7	290.7	1.24
RKP43-5B -...	5	14675	6065	1570	0	108.7	290.7	290.7	1.24

Tab. 36

Type	Number of rollers	Load capacities and moments							Weight [kg]
		C [N]	C _{Orad} [N]	C _{Oax} [N]	M _x [Nm]	M _y [Nm]	M _z [Nm]		
							M _{zd}	M _{zs}	
RFO/RLO63-3-2ZR	3	30750	12500	6000	125	271	367	367	2.44
RFO/RLO63-4A-2ZR	4	30750	12500	7200	250	413	367	1100	3.17
RFO/RLO63-4B-2ZR	4	30750	12500	7200	250	413	1100	367	3.17
RFO/RLO63-5-2ZR	5	36600	15000	8500	250	511	1100	1100	3.89
RFO/RLO63-6A-2ZR	6	36600	15000	10000	350	689	1100	1830	4.60
RFO/RLO63-6B-2ZR	6	36600	15000	10000	350	689	1830	1100	4.60
RKO63-3-2ZR	3	30750	11550	5045	0	235	335	335	2.44
RKO63-4A-2ZR	4	30750	11550	5045	0	294	335	935	3.17
RKO63-4B-2ZR	4	30750	11550	5045	0	294	935	335	3.17
RKO63-5-2ZR	5	36600	13745	6000	0	589	935	935	3.89
RKO63-6A-2ZR	6	36600	13745	6000	0	589	935	1560	4.60
RKO63-6B-2ZR	6	36600	13745	6000	0	589	1560	935	4.60

Tab. 37

Load capacities ROS/RKS

Type	Number of rollers	Load capacities and moments							Weight [kg]
		C [N]	C _{Orad} [N]	C _{Oax} [N]	M _x [Nm]	M _y [Nm]	M _z [Nm]		
							M _{zd}	M _{zs}	
ROS18-060-...	3	1530	820	260	1.5	4.7	8.2	8.2	0.04
ROS18-080-...-A	4	1530	820	300	2.8	7	8.2	24.7	0.05
ROS18-080-...-B	4	1530	820	300	2.8	7	24.7	8.2	0.05
ROS18-100-...	5	1830	975	360	2.8	9.4	24.7	24.7	0.06
ROS18-120-...-A	6	1830	975	440	3.3	11.8	24.7	41.1	0.07
ROS18-120-...-B	6	1830	975	440	3.3	11.8	41.1	24.7	0.07
ROS28-080-...	3	4260	2170	640	6.2	16	27.2	27.2	0.155
ROS28-100-...-A	4	4260	2170	750	11.5	21.7	27.2	81.7	0.195
ROS28-100-...-B	4	4260	2170	750	11.5	21.7	81.7	27.2	0.195
ROS28-125-...	5	5065	2580	900	11.5	29	81.7	81.7	0.24
ROS28-150-...-A	6	5065	2580	1070	13.7	36.2	81.7	136.1	0.29
ROS28-150-...-B	6	5065	2580	1070	13.7	36.2	136.1	81.7	0.29
ROS35-100-...	3	8040	3510	1060	12.9	33.7	61.5	61.5	0.27
ROS35-120-...-A	4	8040	3510	1220	23.9	43.3	52.7	158.1	0.33
ROS35-120-...-B	4	8040	3510	1220	23.9	43.3	158.1	52.7	0.33
ROS35-150-...	5	9565	4180	1460	23.9	57.7	158.1	158.1	0.41
ROS35-180-...-A	6	9565	4180	1780	28.5	72.2	158.1	263.4	0.49
ROS35-180-...-B	6	9565	4180	1780	28.5	72.2	263.4	158.1	0.49
ROS43-120-...	3	12280	5500	1570	23.6	60	104.5	104.5	0.53
ROS43-150-...-A	4	12280	5500	1855	43.6	81.5	104.5	313.5	0.68
ROS43-150-...-B	4	12280	5500	1855	43.6	81.5	313.5	104.5	0.68
ROS43-190-...	5	14675	6540	2215	43.6	108.6	313.5	313.5	0.84
ROS43-230-...-A	6	14675	6540	2645	52	135.8	313.5	522.5	1.01
ROS43-230-...-B	6	14675	6540	2645	52	135.8	522.5	313.5	1.01
RKS43-120-...	3	12280	5100	1320	0	50.4	96.9	96.9	0.53
RKS43-150-A	4	12280	5100	1320	0	54.3	96.9	290.7	0.68
RKS43-150-B	4	12280	5100	1320	0	54.3	290.7	96.9	0.68
RKS43-190-...	5	14675	6065	1570	0	108.7	290.7	290.7	0.84
RKS43-230-A	6	14675	6065	1570	0	108.7	290.7	484.5	1.01
RKS43-230-B	6	14675	6065	1570	0	108.7	484.5	290.7	1.01
ROS63-180-2ZR	3	30750	12500	6000	125	271	367	367	1.66
ROS63-235-2ZR-A	4	30750	12500	7200	250	413	367	1100	2.17
ROS63-235-2ZR-B	4	30750	12500	7200	250	413	1100	367	2.17
ROS63-290-2ZR	5	36600	15000	8500	250	511	1100	1100	2.67
ROS63-345-2ZR-A	6	36600	15000	10000	350	689	1100	1830	3.17
ROS63-345-2ZR-B	6	36600	15000	10000	350	689	1830	1100	3.17
RKS63-180-2ZR	3	30750	11550	5045	0	235	335	335	1.66
RKS63-235-2ZR-A	4	30750	11550	5045	0	294	335	935	2.17
RKS63-235-2ZR-B	4	30750	11550	5045	0	294	935	335	2.17
RKS63-290-2ZR	5	36600	13745	6000	0	589	935	935	2.67
RKS63-345-2ZR-A	6	36600	13745	6000	0	589	935	1560	3.17
RKS63-345-2ZR-B	6	36600	13745	6000	0	589	1560	935	3.17

Tab. 38

Product dimensions



> Rail F, L, K (Rollon T, U, K)

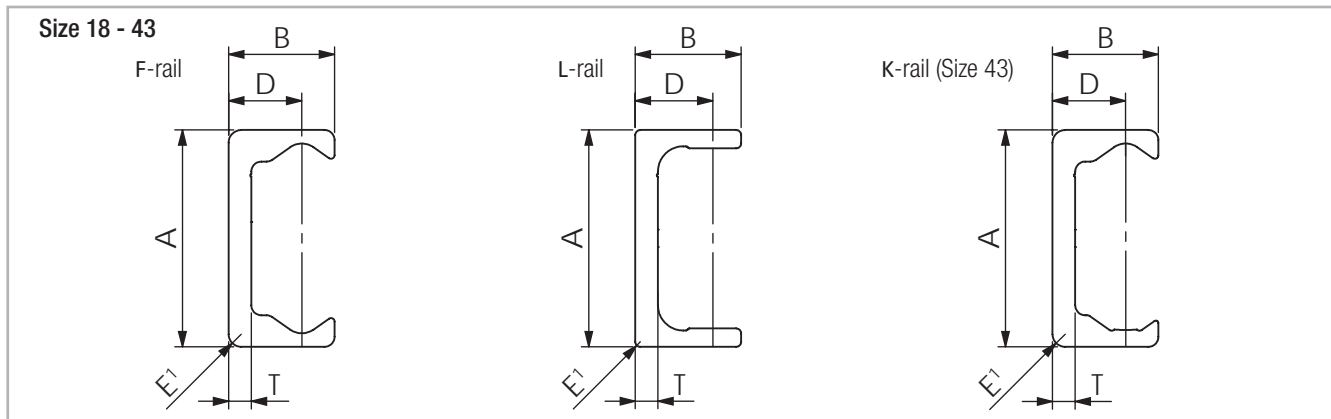

Fig. 105

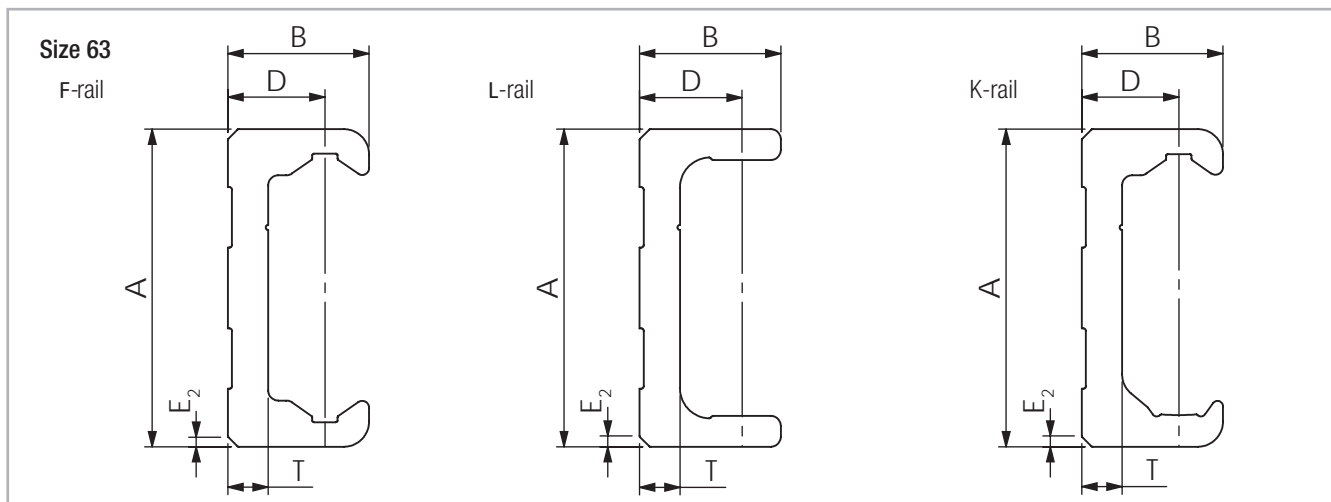

Fig. 106

Holes

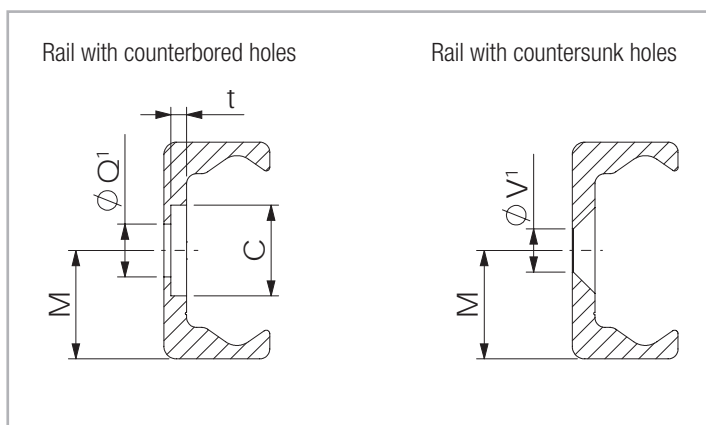

Fig. 107

Q¹ Fixing holes for Torx® screws with low head (custom design) included in scope of supply

V¹ Fixing holes for countersunk head screws according to DIN 7991

Type	Size	A [mm]	B [mm]	D [mm]	M [mm]	E ₁ [mm]	T [mm]	C [mm]	Weight [kg/m]	E ₂ [°]	t [mm]	Q' [mm]	V' [mm]
FRZ FRS	18	18	8.25	5.75	9	1.5	2.8	9.5	0.55	-	2	M4	M4
	28	28	12.25	8.5	14	1	3	11	1.0	-	2	M5	M5
	35	35	16	12	17.5	2	3.5	14.5	1.65	-	2.7	M6	M6
	43	43	21	14.5	21.5	2.5	4.5	18	2.6	-	3.1	M8	M8
	63	63	28	19.25	31.5	-	8	15	6.0	2x45	5.2	M8	M10
LRZ LRS	18	18	8.25	5.75	9	1	2.6	9.5	0.55	-	1.9	M4	M4
	28	28	12	8.5	14	1	3	11	1.0	-	2	M5	M5
	35	35	16	12	17.5	1	3.5	14.5	1.65	-	2.7	M6	M6
	43	43	21	14.5	21.5	1	4.5	18	2.6	-	3.1	M8	M8
	63	63	28	19.25	31.5	-	8	15	6.0	2x45	5.2	M8	M10
KRZ KRS	43	43	21	14.5	21.5	2.5	4.5	18	2.6	-	3.1	M8	M8
	63	63	28	19.25	31.5	-	8	15	6.0	2x45	5.2	M8	M10

Tab. 39

> Rail length

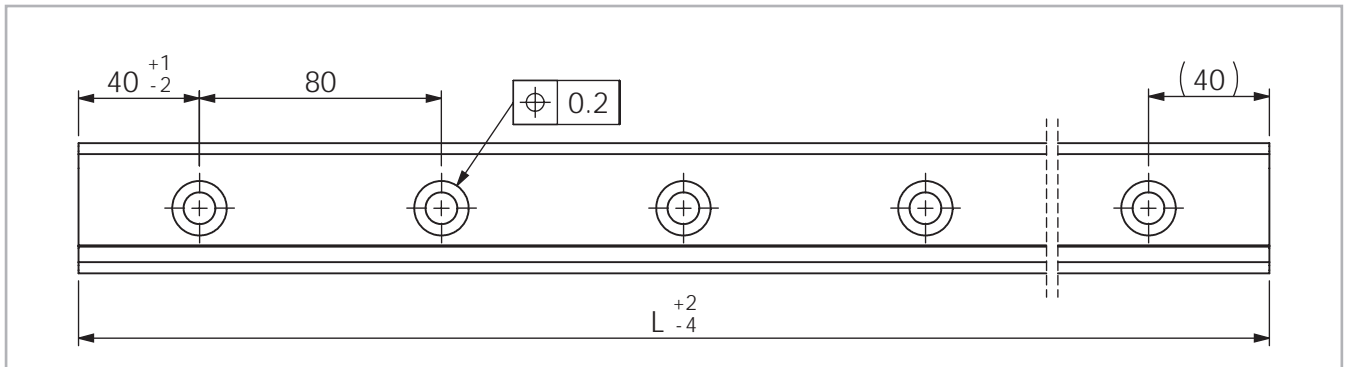

Fig. 108

Type	Size	Min length [mm]	Max length [mm]	Available standard lengths L [mm]
FRZ FRS LRZ LRS	18	160	2000	160 - 240 - 320 - 400 - 480 - 560 - 640 - 720 - 800 - 880 - 960 - 1040 - 1120 - 1200 - 1280 - 1360 - 1440 - 1520 - 1600 - 1680 - 1760 - 1840 - 1920 - 2000 - 2080 - 2160 - 2240 - 2320 - 2400 - 2480 - 2560 - 2640 - 2720 - 2800 - 2880 - 2960 - 3040 - 3120 - 3200 - 3280 - 3360 - 3440 - 3520 - 3600
	28	240	3200	
	35	320	3600	
	43	400	3600	
	63	560	3600	
KRZ KRS	43	400	3600	
	63	560	3600	

Longer single rails up to max. 4,080 mm on request
Longer rail systems see pg. CR-96 Joined rails

Tab. 40

Slider RFO/RLO/RKO-version (Rollon NSW/NSA)

RFO/RLO/RKO-serie

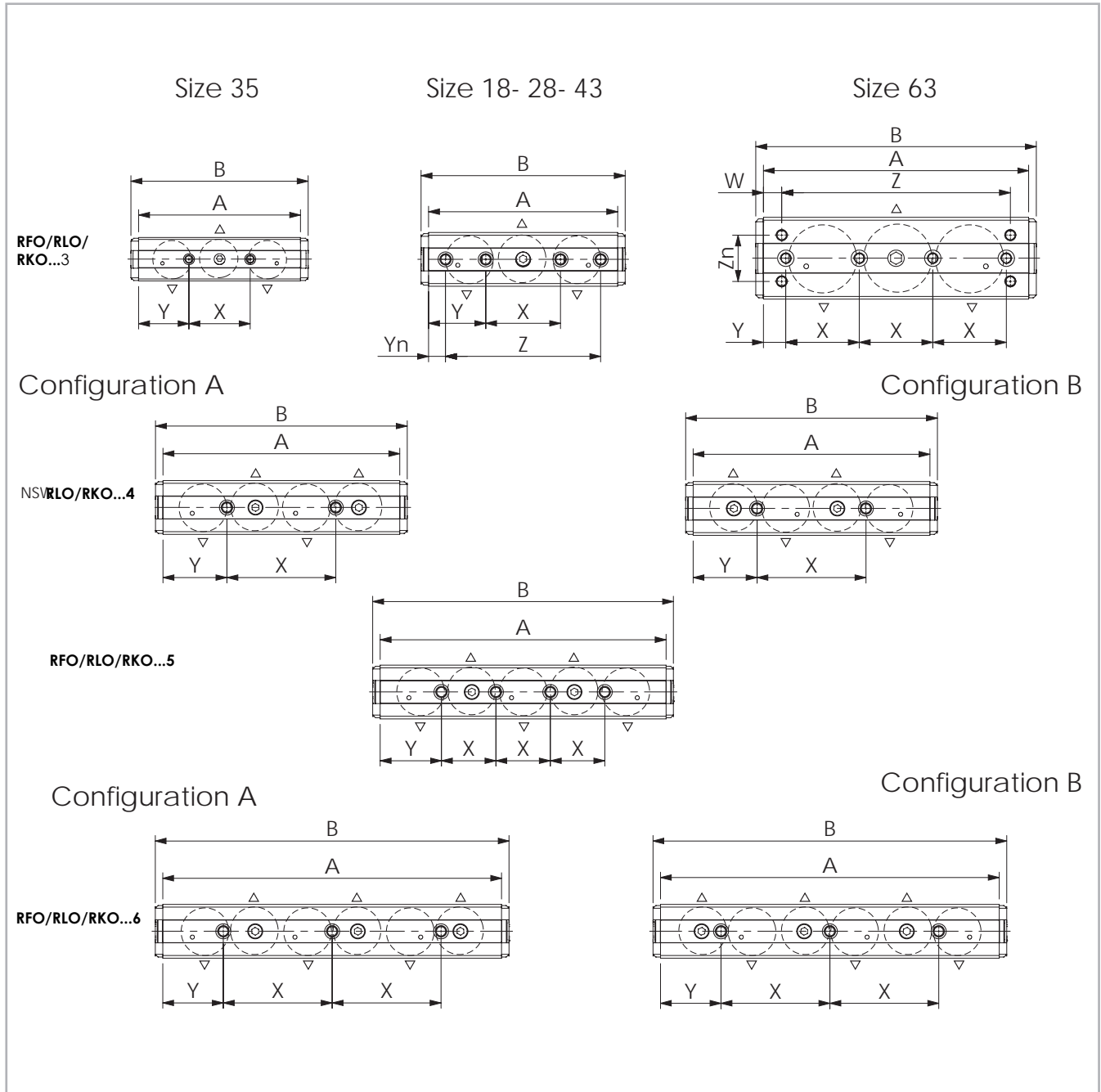

Fig. 109

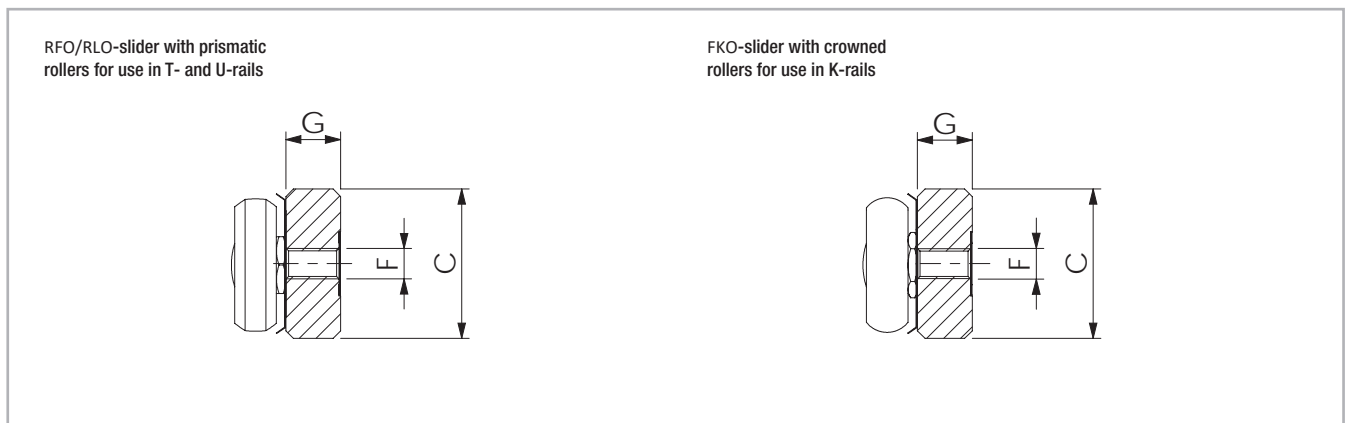

Fig. 110

Type	Size	No. of Rollers	A [mm]	B [mm]	C [mm]	G [mm]	F [mm]	X [mm]	Y [mm]	Z [mm]	Yn [mm]	Zn [mm]	W [mm]	No. of holes	Roller type used*		
RFO/ RLO	18	3	70	78	16	7.2	M5	20	25	52	9	-	-	3	RSPEM18-RSPZM18		
		4	92	100				40	26	-	-			4	RSPEM18		
		5	112	120				20	26	-	-			5	RSPEM18		
		6	132	140				40	26	-	-			6	RSPEM18		
	28	3	97	108	24.9	9.7	M5	35	31	78	9.5	-	-	4	RSPEM28-RSPZM28		
		4	117	128				50	33.5	-	-			2	RSPEM28		
		5	142	153				25	33.5	-	-			4	RSPEM28		
		6	167	178				50	33.5	-	-			3	RSPEM28		
	35	3	119	130	32	11.9	M6	45	37	-	-	-	-	2	RSPEM35-RSPZM35		
		4	139	150				60	39.5					-	-	2	RSPEM35
		5	169	180				30	39.5							4	RSPEM35
		6	199	210				60	39.5							3	RSPEM35
	43	3	139	150	39.5	14.5	M8	55	42	114	12.5	-	-			4	RSPEM43-RSPZM43
		4	174	185				80	47	-	-			2	RSPEM43		
		5	210	221				40	45					-	-	4	RSPEM43
		6	249	260				80	44.5					-	-	3	RSPEM43
	63	3	195	206	60	20.2	M8	54	16.5			168	-	-	34	13.5	4+4
		4	250	261				54	17	-	-	5			RSPEM63		
		5	305	316				54	17.5			-			-	6	RSPEM63
		6	360	371				54	18			-			-	7	RSPEM63
RKO	43	3	139	150	39.5	14.5	M8	55	42			114	12.5	-	-	4	RSREM43-RSRZM43
		4	174	185				80	47	-	-	2	RSREM43				
		5	210	221				40	45			-	-			4	RSREM43
		6	249	260				80	44.5			-	-			3	RSREM43
	63	3	195	206	60	20.2	M8	54	16.5			168	-	-	34	13.5	4+4
		4	250	261				54	17	-	-	5			RSREM63		
		5	305	316				54	17.5			-			-	6	RSREM63
		6	360	371				54	18			-			-	7	RSREM63

* Information about the roller type, see pg. CR-72, tab. 50

Tab. 41

> RFO...L/RLO...L/RKO...L-version slider (Rollon NSW...L/NSA...L)

RFO...L/RLO...L/RKO...L--series version with long body

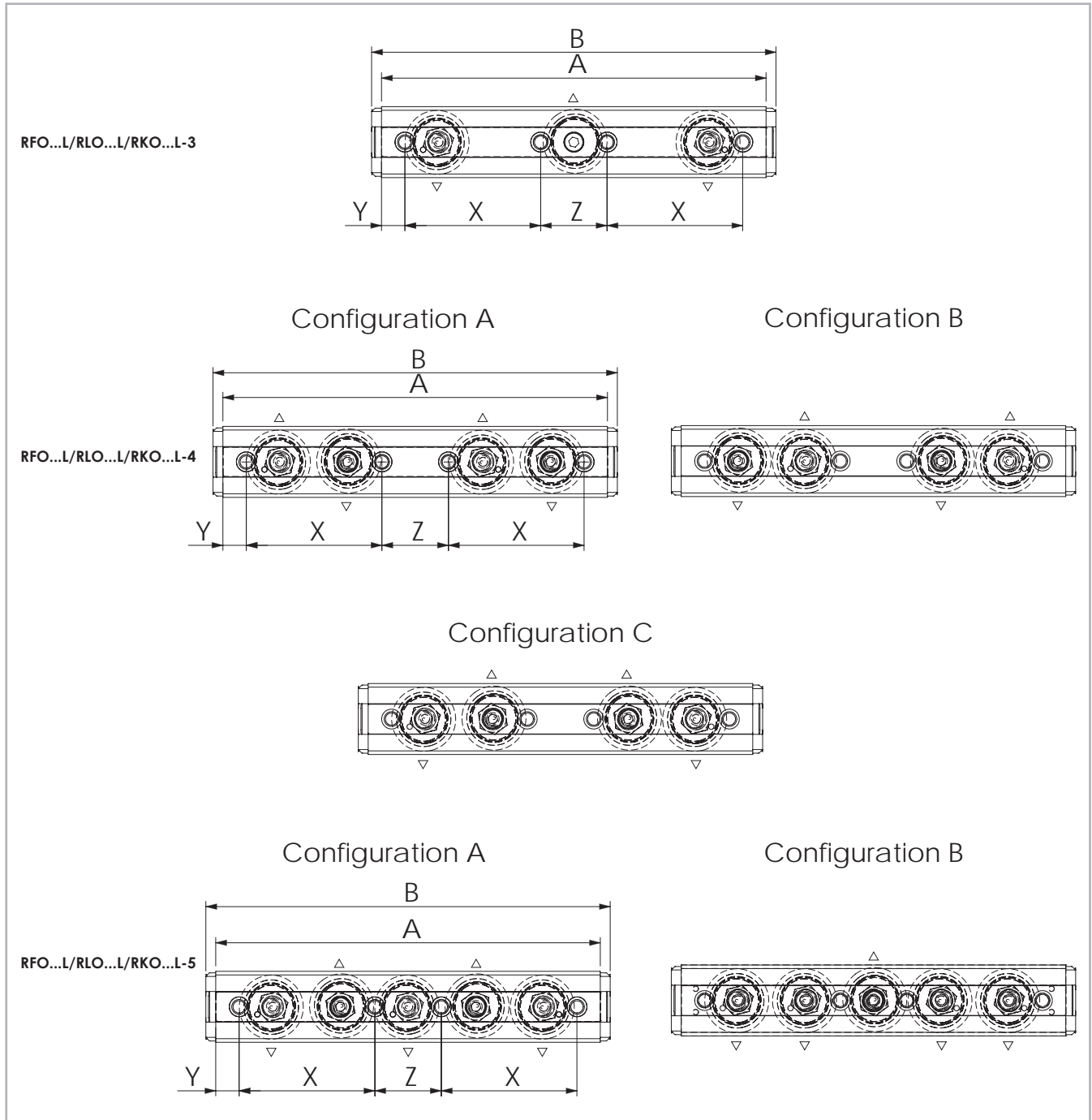

Fig. 111

Type	Size	No. of Rollers	A [mm]	B [mm]	C [mm]	G [mm]	F [mm]	X [mm]	Y [mm]	Z [mm]	No. of holes	Roller type used*
RFO28L/RLO28L	28	3 4 5	149	160	24.9	9.7	M5	52	9.5	26	4	RSPeM28
RFO43L/RLO43L	43	3	214	225	39.5	14.5	M8	75.5	13	37	4	RSPeM43
RKO43L		4 5										RSReM43

Tab. 42

> RFP/RLP/RKP-version slider

RFP/RLP/RKP-series

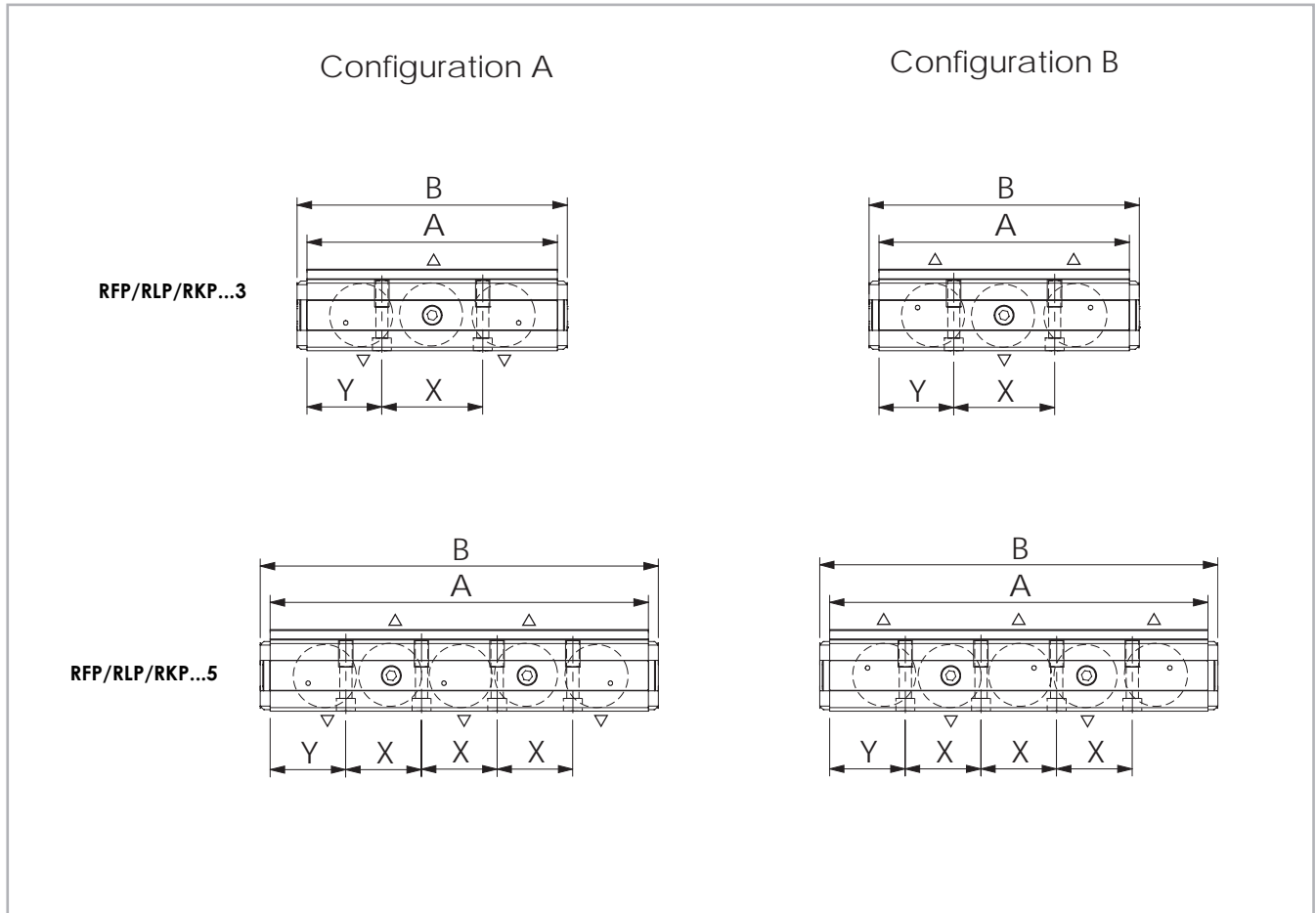

Fig. 112

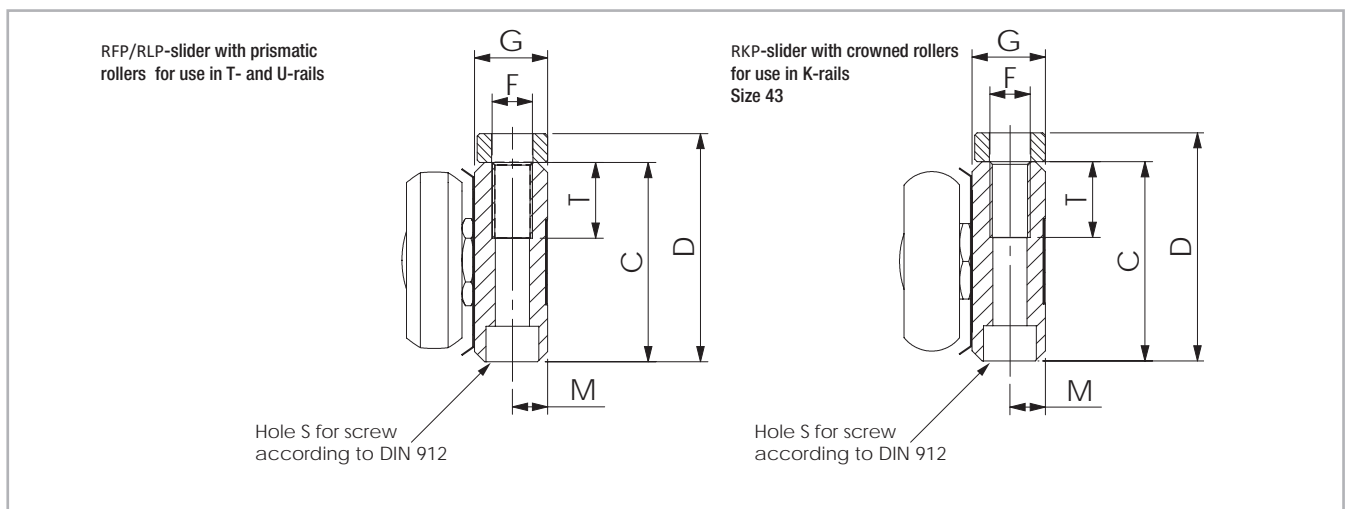

Fig. 113

Type	Size	No. of rollers	A [mm]	B [mm]	C [mm]	D [mm]	G [mm]	M [mm]	S	T [mm]	F [mm]	X [mm]	Y [mm]	No. of holes	Roller type used*
RFP/ RLP	28	3	97	108	24.9	30.45	9.7	4.7	M5	15	M6	36	30.5	2	RSPEM28
		5	142	153								27	30.5	4	RSPEM28
	35	3	119	130	32	36.35	12.4	6	M6	15	M8	45	37	2	RSPEM35
		5	169	180								30	39.5	4	RSPEM35
	43	3	139	150	39.5	45.25	14.5	7	M6	15	M8	56	41.5	2	RSPEM43
		5	210	221								42	42	4	RSPEM43
RKP	43	3	139	150	39.5	45.25	14.5	7	M6	15	M8	56	41.5	2	RSREM43
		5	210	221								42	42	4	RSREM43

* Information about the roller type, see pg. CR-72, tab. 50

Tab. 43

> **R...S-version slider (Rollon CS-Ausführung)**

R...S-series

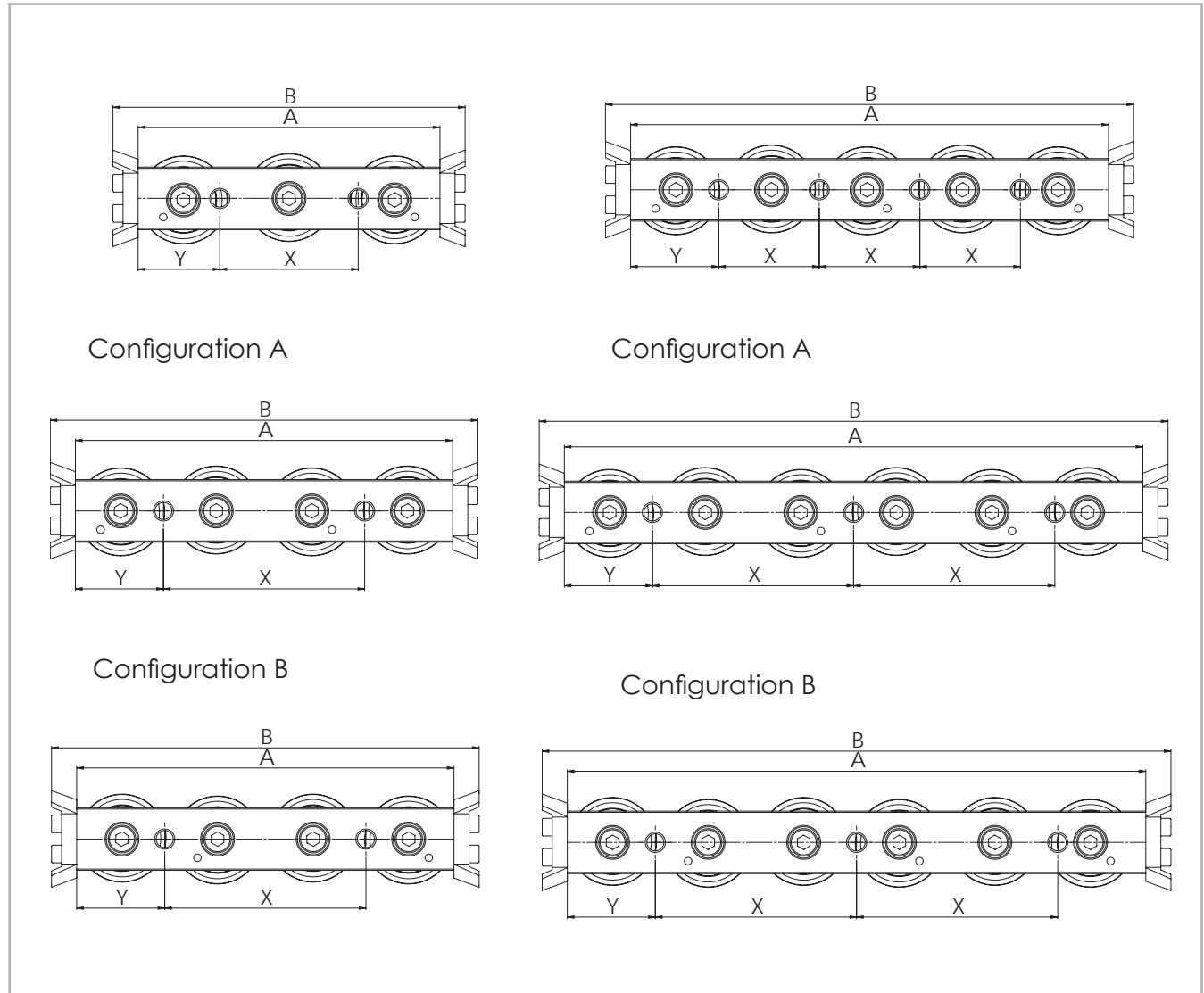

Representation of slider with wiper

Fig. 114

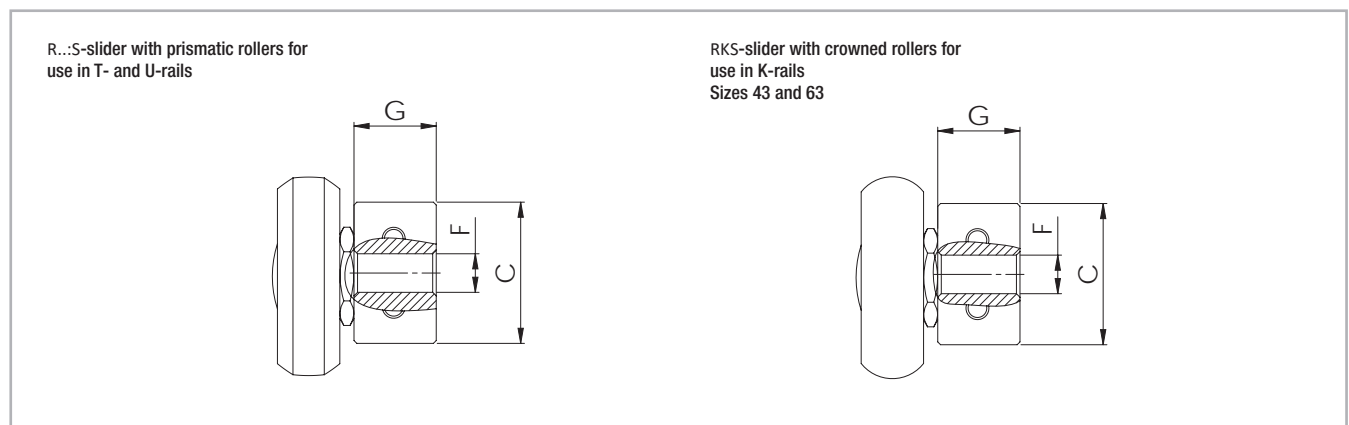

Fig. 115

Type	Size	Number of Rollers	A [mm]	B [mm]	C [mm]	G [mm]	F [mm]	X [mm]	Y [mm]	No. of holes	Roller type used*
RFS / RLS / ROS	18	3	60	76	9.5	5.7	M5	20	20	2	RSPEM18-RSPZM18
		4	80	96	9.5	5.7	M5	40	20	2	RSPEM18
		5	100	116	9.5	5.7	M5	20	20	4	RSPEM18
		6	120	136	9.5	5.7	M5	40	20	3	RSPEM18
	28	3	80	100	14.9	9.7	M5	35	22.5	2	RSPEM28-RSPZM28
		4	100	120	14.9	9.7	M5	50	25	2	RSPEM28
		5	125	145	14.9	9.7	M5	25	25	4	RSPEM28
		6	150	170	14.9	9.7	M5	50	25	3	RSPEM28
	35	3	100	120	19.9	11.9	M6	45	27.5	2	RSPEM35-RSPZM35
		4	120	140	19.9	11.9	M6	60	30	2	RSPEM35
		5	150	170	19.9	11.9	M6	30	30	4	RSPEM35
		6	180	200	19.9	11.9	M6	60	30	3	RSPEM35
	43	3	120	140	24.9	14.5	M8	55	32.5	2	RSPEM43-RSPZM43
		4	150	170	24.9	14.5	M8	80	35	2	RSPEM43
		5	190	210	24.9	14.5	M8	40	35	4	RSPEM43
		6	230	250	24.9	14.5	M8	80	35	3	RSPEM43
	63	3	180	200	39.5	19.5	M8	54	9	4	RSPEM63
		4	235	255	39.5	19.5	M8	54	9.5	5	RSPEM63
		5	290	310	39.5	19.5	M8	54	10	6	RSPEM63
		6	345	365	39.5	19.5	M8	54	10.5	7	RSPEM63
RKS	43	3	120	140	24.9	14.5	M8	55	32.5	2	RSREK43-RSRZK43
		4	150	170	24.9	14.5	M8	80	35	2	RSREK43
		5	190	210	24.9	14.5	M8	40	35	4	RSREK43
		6	230	250	24.9	14.5	M8	80	35	3	RSREK43
	63	3	180	200	39.5	19.5	M8	54	9	4	RSREK63
		4	235	255	39.5	19.5	M8	54	9.5	5	RSREK63
		5	290	310	39.5	19.5	M8	54	10	6	RSREK63
		6	345	365	39.5	19.5	M8	54	10.5	7	RSREK63

* Information about the roller type, see pg. CR-72, tab. 50

Tab. 44

> F-rail with RFO/RFP-slider (Rollon T-rail with NSW/NSD-slider)

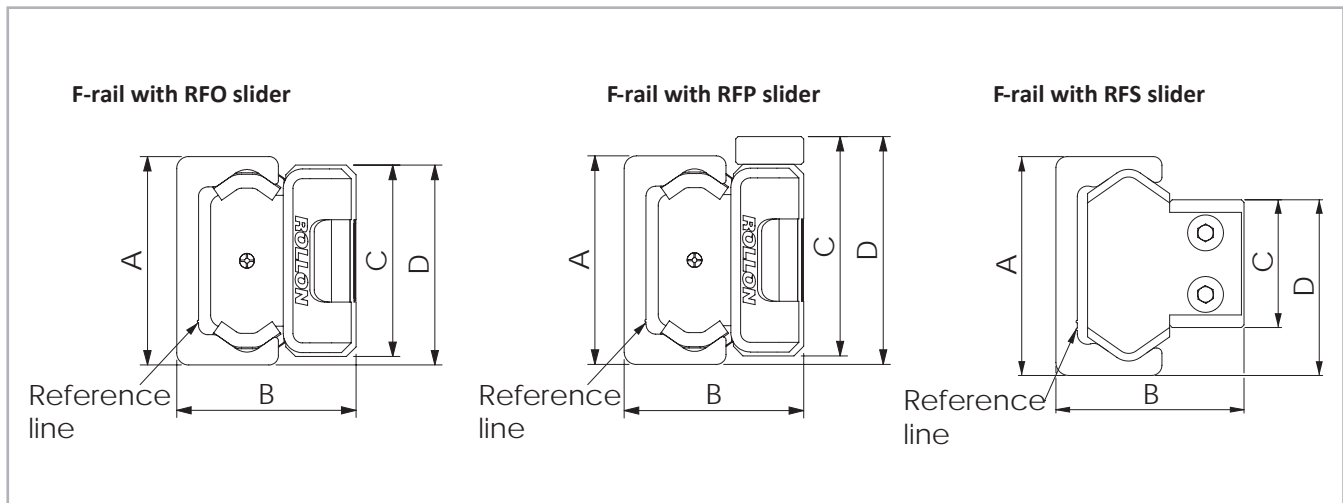

Fig. 116

Configuration	Size	A [mm]		B [mm]		C [mm]		D [mm]	
FR... / RFO	18	18	+0.2 -0.10	16.5	±0.15	16	0 -0.2	17	+0.1 -0.3
	28	28	+0.2 -0.10	23.9	±0.15	24.9	0 -0.2	26.45	+0.1 -0.3
	35	35	+0.35 -0.10	30.2	±0.15	32	0 -0.2	33.5	+0.2 -0.4
	43	43	+0.3 -0.10	37	±0.15	39.5	0 -0.2	41.25	+0.2 -0.4
	63	63	+0.3 -0.10	50.5	±0.15	60	0 -0.2	61.5	+0.2 -0.4
FR... / RFP	28	28	+0.2 -0.10	23.9	±0.15	24.9	0 -0.2	32	+0.1 -0.3
	35	35	+0.35 -0.10	30.2	±0.15	32	0 -0.2	37.85	+0.2 -0.4
	43	43	+0.3 -0.10	37	±0.15	45.25	0 -0.2	47	+0.2 -0.4
FR... / RFS	18	18	+0.25 -0.10	15	+0.15 -0.15	9.5	0 -0.05	14	+0.05 -0.25
	28	28	+0.25 -0.10	23.9	+0.15 -0.15	14.9	0 -0.10	21.7	+0.05 -0.35
	35	35	+0.35 -0.10	30.2	+0.10 -0.30	19.9	+0.05 -0.15	27.85	+0.10 -0.30
	43	43	+0.35 -0.10	37	+0.15 -0.15	24.9	0 -0.15	34.3	+0.10 -0.30
	63	63	+0.35 -0.10	49.8	+0.15 -0.15	39.5	+0.15 0	51.6	+0.15 -0.30

Tab. 45

> L-rail with RLO/RLP-slider (Rollon NSW / NSD / CS slider)

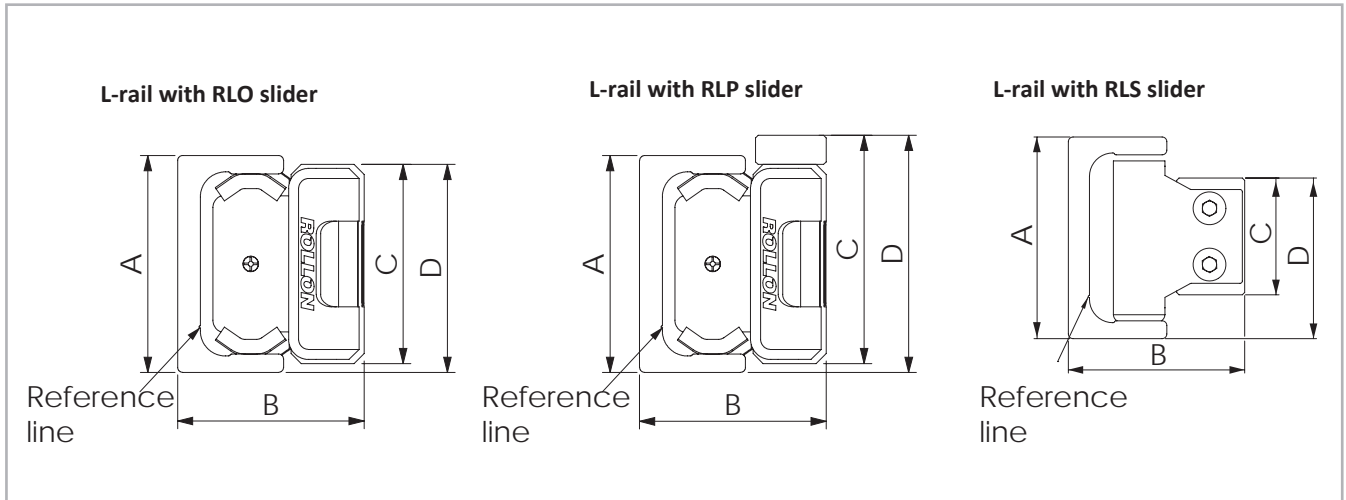
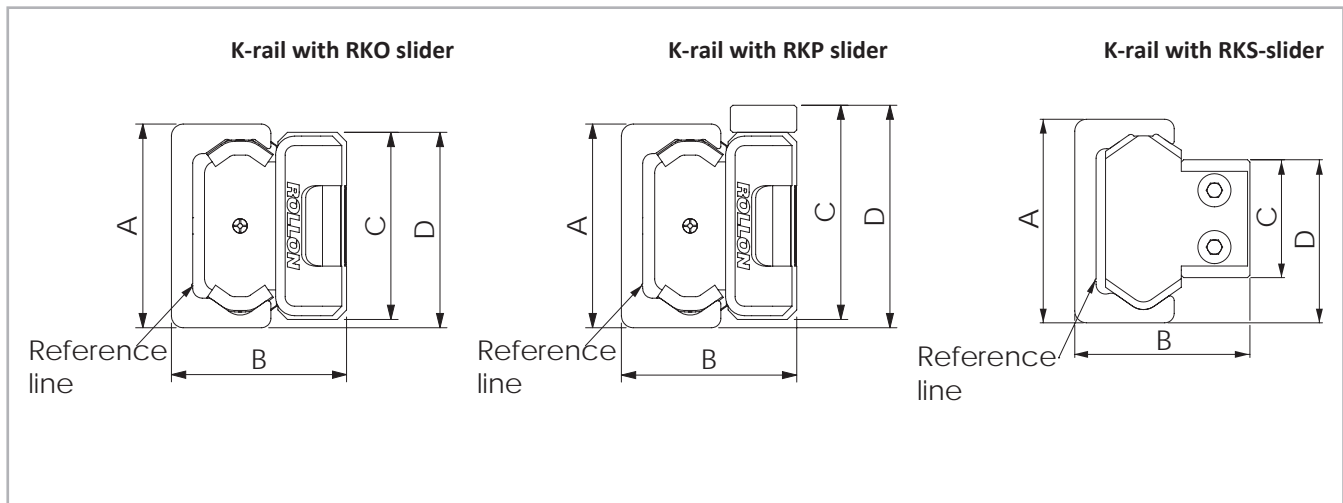

Fig. 117

Configuration	Size	A [mm]		B _{nom} * [mm]	C [mm]		D [mm]	
LR... / RLO	18	18	+0.25 -0.10	15	16	0 -0.2	17	+0.1 -0.3
	28	28	+0.25 -0.10	23.9	24.9	0 -0.2	26.45	+0.1 -0.3
	35	35	+0.35 -0.10	30.2	32	0 -0.2	33.5	+0.2 -0.4
	43	43	+0.35 -0.10	37	39.5	0 -0.2	41.25	+0.2 -0.4
	63	63	+0.35 -0.10	50.5	60	0 -0.2	61.5	+0.2 -0.4
LR... / RLP	28	28	+0.25 -0.10	23.9	24.9	0 -0.2	32	+0.1 -0.3
	35	35	+0.35 -0.10	30.2	32	0 -0.2	37.85	+0.2 -0.4
	43	43	+0.35 -0.10	37	45.25	0 -0.2	47	+0.2 -0.4
LR... / RLS	18	18	+0.25 -0.10	15	9.5	0 -0.05	14	+0.05 -0.25
	28	28	+0.25 -0.10	23.9	14.9	0 -0.10	21.7	+0.05 -0.35
	35	35	+0.35 -0.10	30.2	19.9	+0.05 -0.15	27.85	+0.10 -0.30
	43	43	+0.35 -0.10	37	24.9	0 -0.15	34.3	+0.15 -0.30
	63	63	+0.35 -0.10	49.8	39.5	+0.15 0	51.6	+0.15 -0.30

Tab. 46

> **K-rail with RKO/RKP/RKS-slider (Rollon NSA / NSDA / CSK slider)**



The K-rail enables the slider to rotate around its longitudinal axis (see pg. CR-80)

Fig. 118

Configuration	Size	A [mm]		B [mm]		C [mm]		D [mm]	
KR... / RKO	43	43	+0.35 -0.1	37	±0.15	39.5	0 -0.2	41.25	+0.2 -0.4
	63	63	+0.35 -0.1	50.5	±0.15	60	0 -0.2	61.5	+0.2 -0.4
KR... / RKP	43	43	+0.35 -0.1	37	±0.15	45.25	0 -0.2	41.25	+0.2 -0.4
KR... / RKS	43	43	+0.35 -0.10	37	+0.15 -0.15	24.9	0 -0.15	34.3	+0.10 -0.30
	63	63	+0.35 -0.10	49.8	+0.15 -0.15	39.5	+0.15 0	51.6	+0.15 -0.30

Tab. 47

> Offset of fixing holes

Principle representation of offset

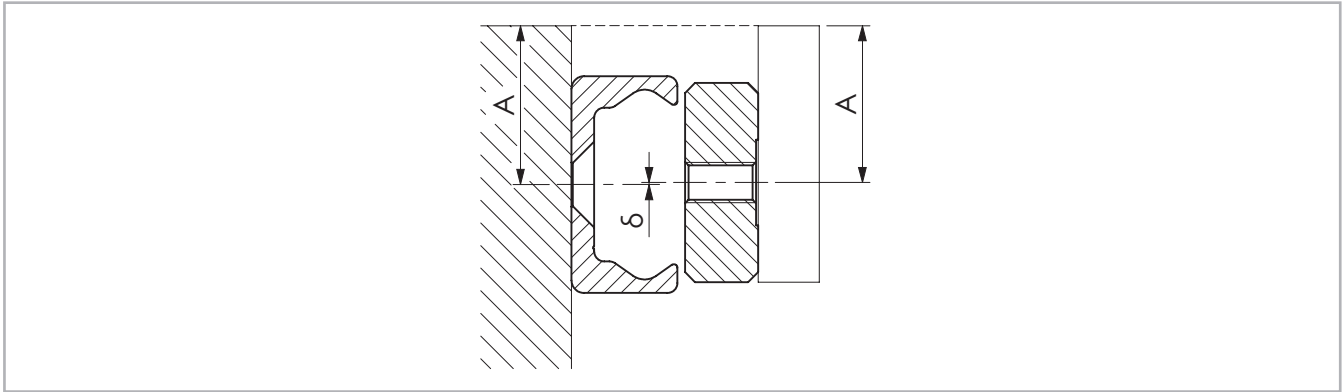

Fig. 119

Configura-tion	Size	δ nominal [mm]	δ maximum [mm]	δ minimum [mm]	Configura-tion	Size	δ nominal [mm]	δ maximum [mm]	δ minimum [mm]
FRZ / RFO	18	0	+0.5	-0.5	FRZ / ROS	18	0.35	+0.75	-0.2
	28		+0.5	-0.5		28	0.25	0.6	-0.35
	35		+0.6	-0.6		35	0.35	+0.7	-0.35
	43		+0.6	-0.6		43	0.35	+0.8	-0.35
	63		+0.65	-0.65		63	0.35	+0.6	-0.35
KRZ / RKO	43		+0.6	-0.6	KRZ / RKS	43	0.35	+0.8	-0.35
	63		+0.65	-0.65		63	0.35	+0.6	-0.35
LRZ / RLO	18		+0.5	-0.5	LRZ / ROS	18	0.3	+0.7	-0.2
	28		+0.5	-0.5		28	0.3	+0.6	-0.3
	35		+0.6	-0.6		35	0.35	+0.7	-0.35
	43		+0.6	-0.6		43	0.4	+0.75	-0.35
	63		+0.65	-0.65		63	0.35	+0.6	-0.25
FRS / RFO	18		+0.35	-0.35	FRS / ROS	18	0.35	+0.6	-0.15
	28		+0.35	-0.35		28	0.25	+0.45	-0.3
	35		+0.45	-0.45		35	0.35	+0.55	-0.3
	43		+0.45	-0.45		43	0.35	+0.65	-0.3
	63		+0.5	-0.5		63	0.35	+0.45	-0.35
KRS / RKO	43		+0.45	-0.45	KRS / RKS	43	0.35	+0.65	-0.3
	63		+0.5	-0.5		63	0.35	+0.45	-0.35
LRS / RLO	18		+0.35	-0.35	LRS / ROS	18	0.3	+0.55	-0.15
	28	+0.35	-0.35	28		0.3	+0.45	-0.25	
	35	+0.45	-0.45	35		0.35	+0.55	-0.3	
	43	+0.45	-0.45	43		0.4	+0.6	-0.3	
	63	+0.5	-0.5	63		0.35	+0.45	-0.25	

Tab. 48

Tab. 49

Accessories



> Rollers

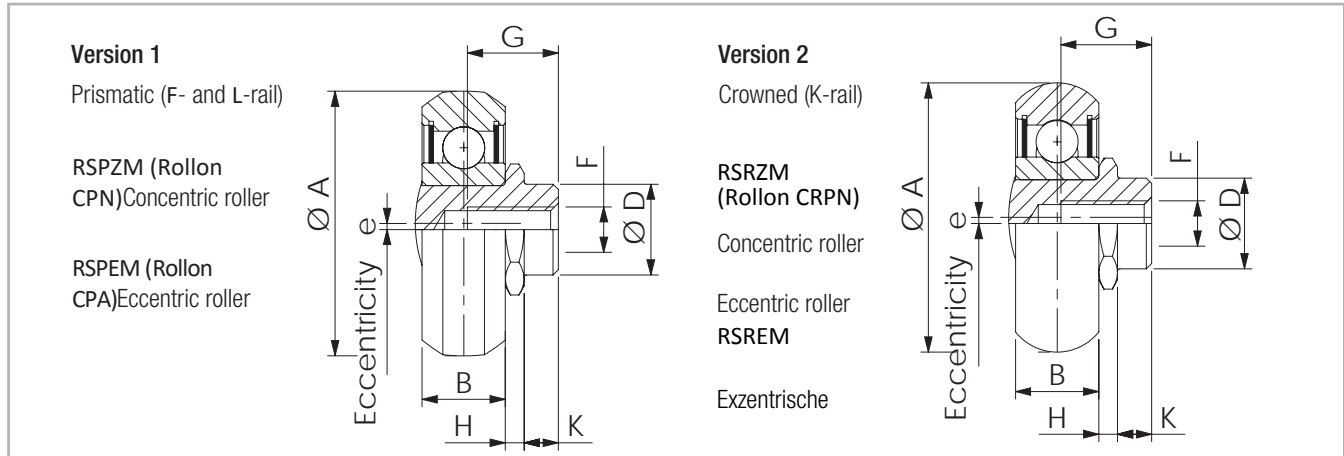

Seals: 2RS is the splash-proof seal, 2Z (2ZR for size 63) is the steel cover disc
Note: The rollers are lubricated for life

Fig. 120

Type		A [mm]	B [mm]	D [mm]	e [mm]	H [mm]	K [mm]	G [mm]	F	C [N]	C _{Orad} [N]	Weight [kg]
Steel	Inox											
RSPZM18-2RS	REPZM18-2RS	14	4	6	-	1.55	1.8	5.5	M4	765	410	0.004
RSPZM18-2Z	-	14	4	6	-	1.55	1.8	5.5	M4	765	410	0.004
RSPEM18-2RS	REPEM18-2RS	14	4	6	0.4	1.55	1.8	5.5	M4	765	410	0.004
RSPEM18-2Z	-	14	4	6	0.4	1.55	1.8	5.5	M4	765	410	0.004
RSPZM28-2RS	REPZM28-2RS	23.2	7	10	-	2.2	3.8	7	M5	2130	1085	0.019
RSPZM28-2Z	-	23.2	7	10	-	2.2	3.8	7	M5	2130	1085	0.019
RSPEM28-2RS	REPEM28-2RS	23.2	7	10	0.6	2.2	3.8	7	M5	2130	1085	0.019
RSPEM28-2Z	-	23.2	7	10	0.6	2.2	3.8	7	M5	2130	1085	0.019
RSPZM35-2RS	REPZM35-2RS	28.2	7.5	12	-	2.55	4.2	9	M5	4020	1755	0.032
RSPZM35-2Z	-	28.2	7.5	12	-	2.55	4.2	9	M5	4020	1755	0.032
RSPEM35-2RS	REPEM35-2RS	28.2	7.5	12	0.7	2.55	4.2	9	M5	4020	1755	0.032
RSPEM35-2Z	-	28.2	7.5	12	0.7	2.55	4.2	9	M5	4020	1755	0.032
RSPZM43-2RS	REPZM43-2RS	35	11	12	-	2.5	4.5	12	M6	6140	2750	0.06
RSPZM43-2Z	-	35	11	12	-	2.5	4.5	12	M6	6140	2750	0.06
RSPEM43-2RS	REPEM43-2RS	35	11	12	0.8	2.5	4.5	12	M6	6140	2750	0.06
RSPEM43-2Z	-	35	11	12	0.8	2.5	4.5	12	M6	6140	2750	0.06
RSPZM63-2ZR	REPZM63-2RSR	50	17.5	18	-	2.3	6	16	M8	15375	6250	0.19
RSPEM63-2ZR	REPEM63-2RSR	50	17.5	18	1.2	2.3	6	16	M10	15375	6250	0.19
RSRZM43-2Z	RERZM43-2RS	35.6	11	12	-	2.5	4.5	12	M6	6140	2550	0.06
RSREM43-2Z	REREM43-2RS	35.6	11	12	0.8	2.5	4.5	12	M6	6140	2550	0.06
RSRZM63-2ZR	RERZM63-2RS	49.7	17.5	18	-	2.3	6	16	M8	15375	5775	0.19
RSREM63-2ZR	REREM63-2RS	49.7	17.5	18	1.2	2.3	6	16	M10	15375	5775	0.19

Tab. 50

> Wipers

Wipers for RFO / RLO / RKO / RFP / RLP / RKP

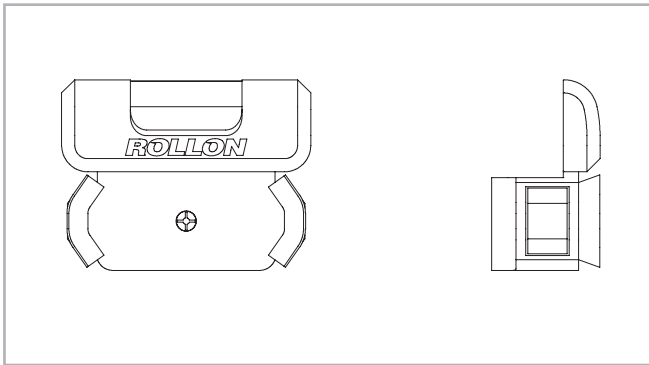

Fig. 121

Rail size	Pair of wipers
18	ZK-WNS18
28	ZK-WNS28
35	ZK-WNS35
43	ZK-WNS43
63	ZK-WNS63

Tab. 51

Wipers for ROS / RKS

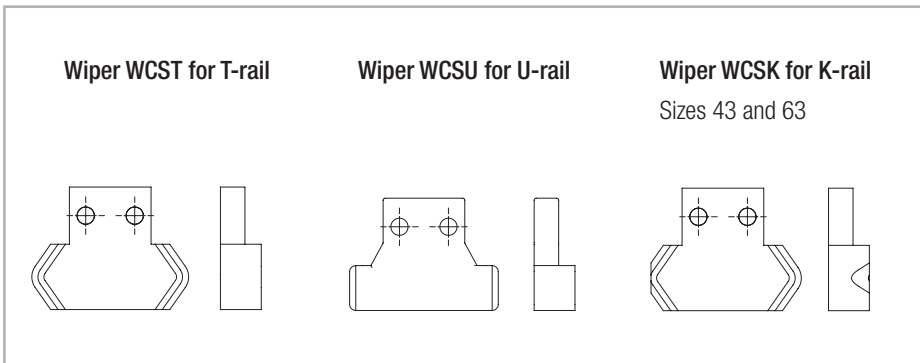

Fig. 122

Rail size	Pair of wipers
18	ZK-WCS...18
28	ZK-WCS...28
35	ZK-WCS...35
43	ZK-WCS...43
63	ZK-WCS...63

Tab. 52

> Alignment fixture AT (for F- and L-rail)

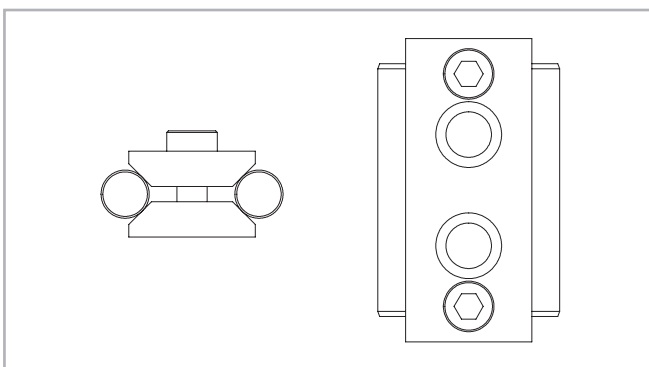

Fig. 123

Rail size	Alignment fixture
18	AT 18
28	AT 28
35	AT 35
43	AT 43
63	AT 63

Tab. 53

> Alignment fixture AK (for K-rail)

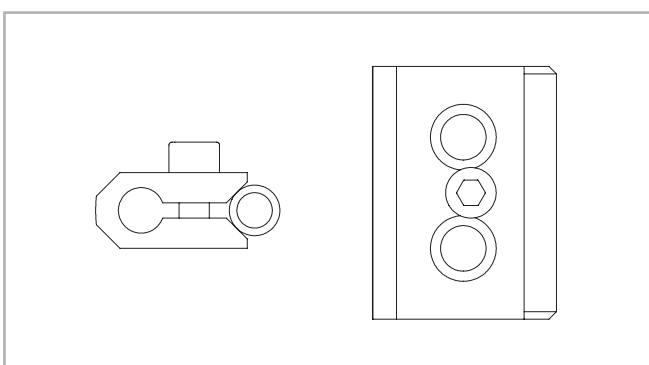

Fig. 124

Rail size	Alignment fixture
43	AK 43
63	AK 63

Tab. 54

> Fixing screws

When a rail with counterbored holes is delivered, the Torx® screws are provided in the right quantity.

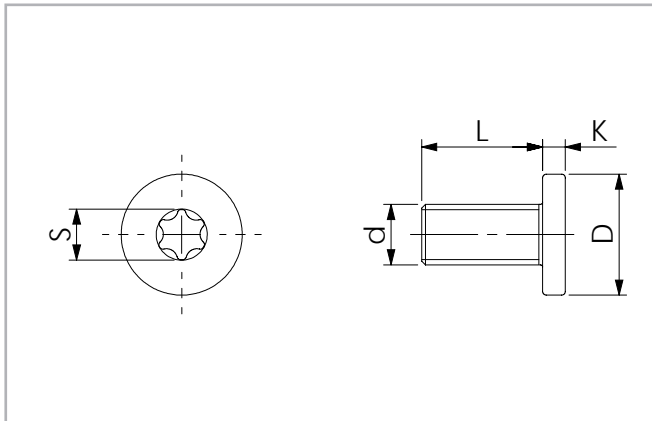

Fig. 125

Rail size	d	D [mm]	L [mm]	K [mm]	S	Tightening torque [Nm]
18	M4 x 0.7	8	8	2	T20	3
28	M5 x 0.8	10	10	2	T25	9
35	M6 x 1	13	13	2,7	T30	12
43	M8 x 1.25	16	16	3	T40	22
63	M8 x 1.25	13	20	5	T40	35

Tab. 55

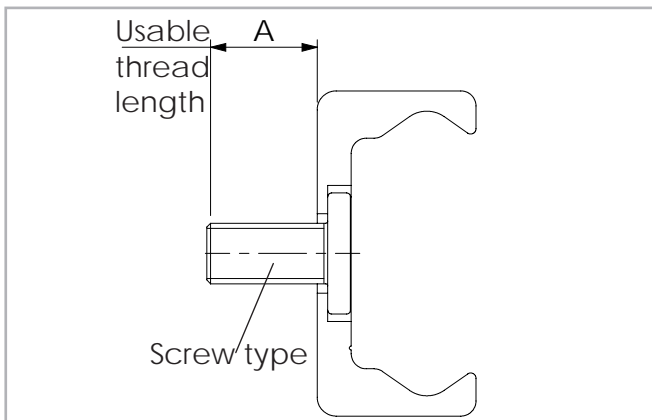

Fig. 126

Rail size	Screw type	Usable thread length [mm]
18	M4 x 8	7.2
28	M5 x 10	9
35	M6 x 13	12.2
43	M8 x 16	14.6
63	M8 x 20	17.2

Tab. 56

> Manual clamp elements

Compact Rail guides can be secured with manual clamping elements. Areas of application are:

- Table cross beams and sliding beds
- Width adjustment, stops
- Positioning of optical equipment and measuring tables

The HK series is a manually activated clamping element. By using the freely adjustable clamping lever (except for HK 18, which uses hexagon socket bolt M6 DIN 913 with 3 mm drive) press the contact profile synchronously on the free surfaces of the rail. The floating mounted contact profiles guarantee symmetrical introduction of force on the guide rail.

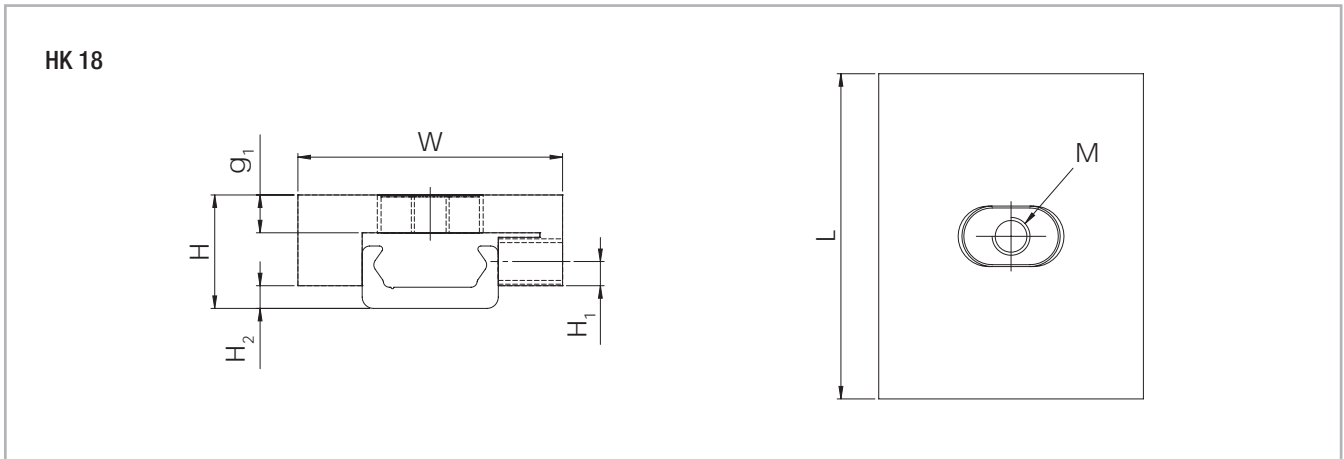

Fig. 127

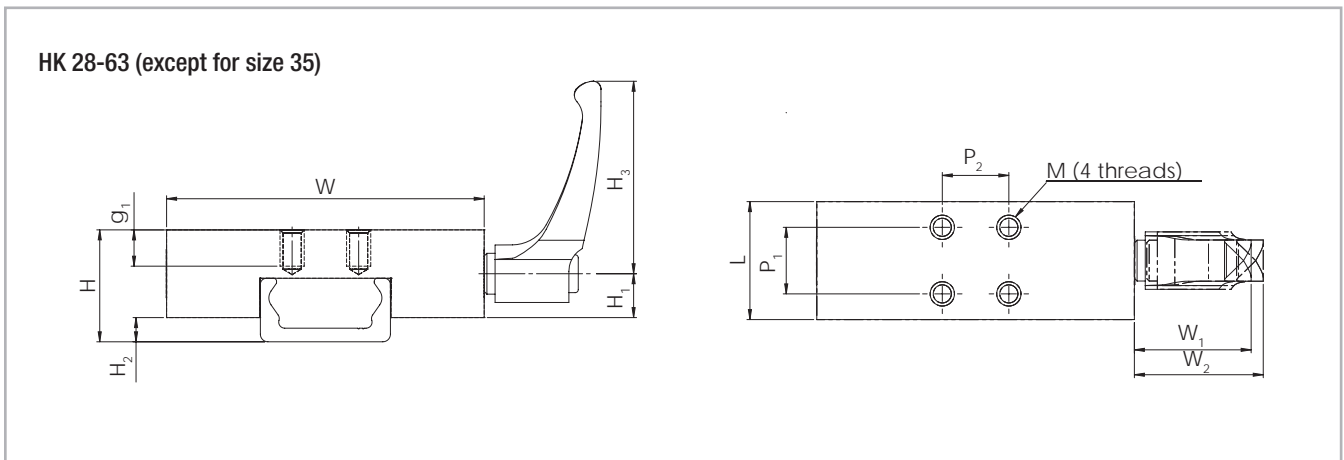

Fig. 128

Type	Size	Holding force [N]	Tightening torque [Nm]	Dimensions [mm]											M
				H	H ₁	H ₂	H ₃	W	W ₁	W ₂	L	P ₁	P ₂	g ₁	
HK1808A	18	150	0.5	15	3.2	3	-	35	-	-	43	0	0	6	M5
HK2808A	28	1200	7	24	17	5	64	68	38.5	41.5	24	15	15	6	M5
HK4308A	43	2000	15	37	28.5	8	78	105	46.5	50.5	39	22	22	12	M8
HK6308A	63	2000	15	50.5	35	9.5	80	138	54.5	59.5	44	26	26	12	M8

Tab. 57

Technical instructions



> Linear accuracy

Linear accuracy is defined as the maximum deviation of the slider in the rail based on the side and support surface during straight line movement.

The linear accuracy, depicted in the graphs below, applies to rails that are carefully installed with all the provided screws on a level and rigid foundation.

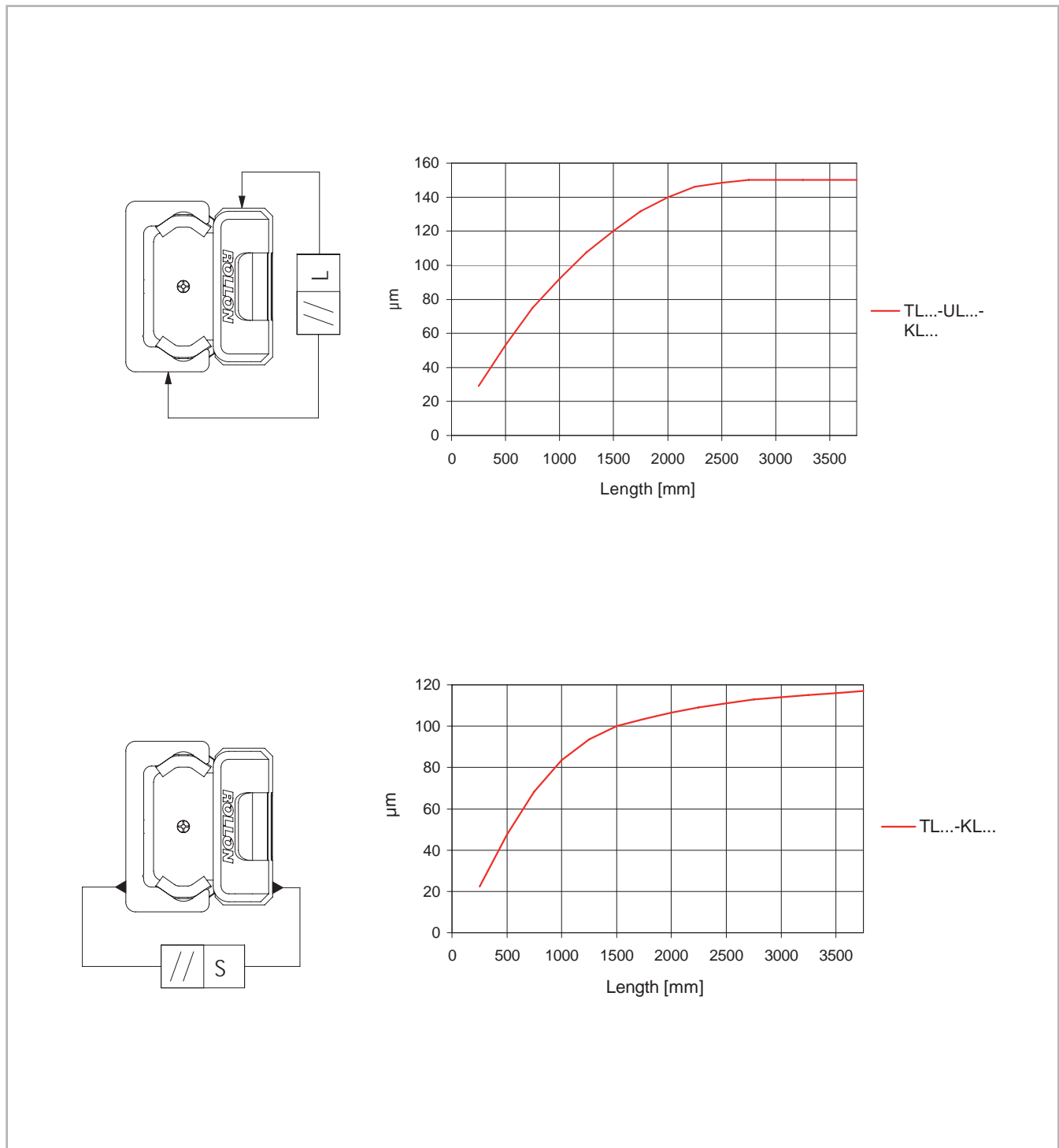
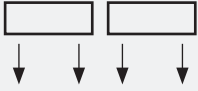
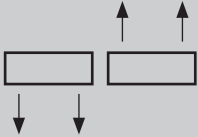

Fig. 129

Deviation of accuracy with two 3 roller sliders in one rail

Type	TL..., UL..., KL...
ΔL [mm] Slider with equal arrangement 	0.2
ΔL [mm] Slider with opposite arrangement 	1.0
ΔS [mm]	0.05

Tab. 58

> Supported sides

If a higher system rigidity is required, a support of the rail sides is recommended, which can also be used as the reference surface (see fig. 130). The minimum required support depth can be taken from the adjacent table (see tab. 59).

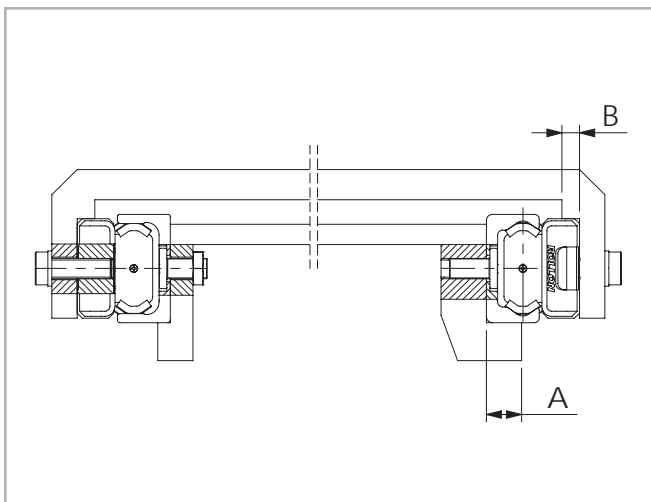

Fig. 130

Rail size	A [mm]	B [mm]
18	5	4
28	8	4
35	11	5
43	14	5
63	18	5

Tab. 59

> F+L-system tolerance compensation

Axial deviations in parallelism

This problem occurs fundamentally by insufficient precision in the axial parallelism of the mounting surfaces, which results in an excessive load on the slider and thus causes drastically reduced service life.

The use of fixed bearing and compensating bearing rail (F+L-system) solves the unique problem of aligning two track, parallel guide systems. By using a F+L-system, the T-rail takes over the motion of the track while the U-rail serves as a support bearing and takes only radial forces and M_2 moments.



Fig. 131

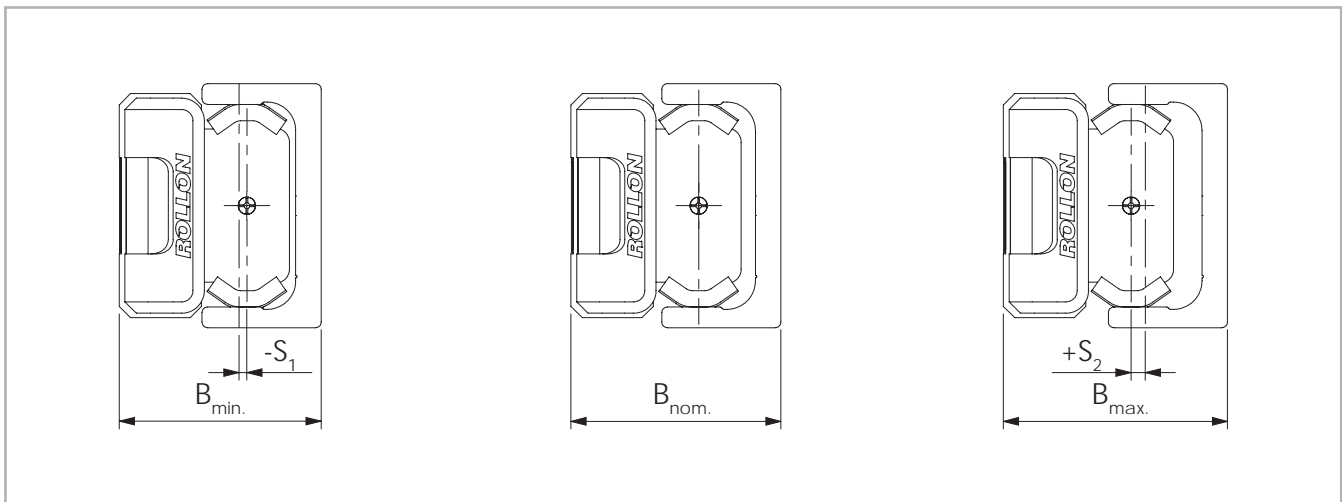

Fig. 132

F+L-system maximum offset

U-rails have flat parallel raceways that allow free lateral movement of the sliders. The maximum axial offset that can be compensated for in each slider of the U-rail is made up of the combined values S_1 and S_2 listed in table 60. Considered from a nominal value B_{nom} as the starting point, S_1 indicates the maximum offset into the rail, while S_2 represents the maximum offset towards the outside of the rail.

Slider type	S_1 [mm]	S_2 [mm]	B_{min} [mm]	B_{nom} [mm]	B_{max} [mm]
RFO/RLO18	0.3	1.1	16.2	16.5	17.6
RFO/RLO28 RFP/RLP28	0.6	1.3	23.3	23.9	25.2
RFO/RLO35 RFP/RLP35	1.3	2.7	28.9	30.2	32.9
RFO/RLO43 RFP/RLP43	1.4	2.5	35.6	37	39.5
RFP/RLO63	0.4	3.5	50.1	50.5	54
ROS18	0.3	1.1	14.7	15	16.1
ROS28	0.6	1.3	23.3	23.9	25.2
ROS35	1.3	2.7	28.9	30.2	32.9
ROS43	1.4	2.5	35.6	37	39.5
ROS63	0.4	3.5	49.4	49.8	53.3

Tab. 60

The application example in the adjacent drawing (see fig. 134) shows that the F+L-system implements a problem-free function of the slider even with an angled offset in the mounting surfaces.

If the length of the guide rails is known, the maximum allowable angle deviation of the screwed surfaces can be determined using this formula (the slider in the U-rail moves here from the innermost position S_1 to outermost position S_2):

$\alpha = \arctan \frac{S^*}{L}$	$S^* = \text{Sum of } S_1 \text{ and } S_2$ $L = \text{Length of rail}$
----------------------------------	---

Fig. 133

The following table (tab. 61) contains guidelines for this maximum angle deviation α , achievable with the longest guide rail from one piece.

Size	Rail length [mm]	Offset S [mm]	Angle α [°]
18	2000	1.4	0.040
28	3200	1.9	0.034
35	3600	4	0.063
43	3600	3.9	0.062
63	3600	3.9	0.062

Tab. 61

The F+L-system can be designed in different arrangements (see fig. 135). A T-rail accepts the vertical components of load A U-rail attached underneath the component to be guided prevents the vertical panel from swinging and is used as moment support. In addition, a vertical offset in the structure, as well as possible existing unevenness of the support surface, is compensated.

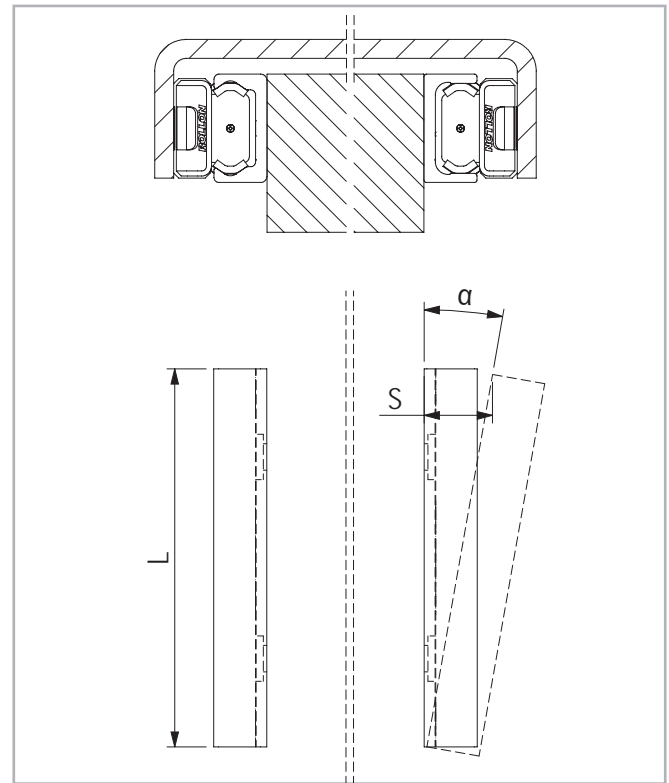

Fig. 134



Fig. 135

> K+U-system tolerance compensation

Deviations in parallelism in two planes

The K+U-system, like the F+L-system, can compensate for axial deviations in parallelism. Additionally, the K+U system has the option of rotating the slider in the rail, which will compensate for other deviations in parallelism, e.g. height offset.

The unique raceway contour of the K-rail allows the slider a certain rotation around its longitudinal axis, with the same linear precision as with a T-rail. With the use of a K+U-system, the K-rail accounts for the main loads and the motion of the track. The U-rail is used as a support bearing and takes only radial forces and M_z moments. The K-rail must always be installed so that the radial load of the slider is always supported by at least 2 load bearing roller sliders, which lie on the V-shaped raceway (reference line) of the rail.



Fig. 136

K-rails and sliders are available in both sizes 43 and 63. The custom NSA-slider may only be used in K-rails and cannot be exchanged with other Rollon sliders. The maximum allowable rotation angle of the NSA- and NSW-sliders are shown in the following table 62 and figure 137. α_1 is the maximum rotation angle counterclockwise, α_2 is clockwise.

Slider type	α_1 [°]	α_2 [°]
RKO43 und RLO43 / R...S43	2	2
RKO63 und RLO63 / R...S63	1	1

Values referred to NSW and CSW slider in U rail

Tab. 62

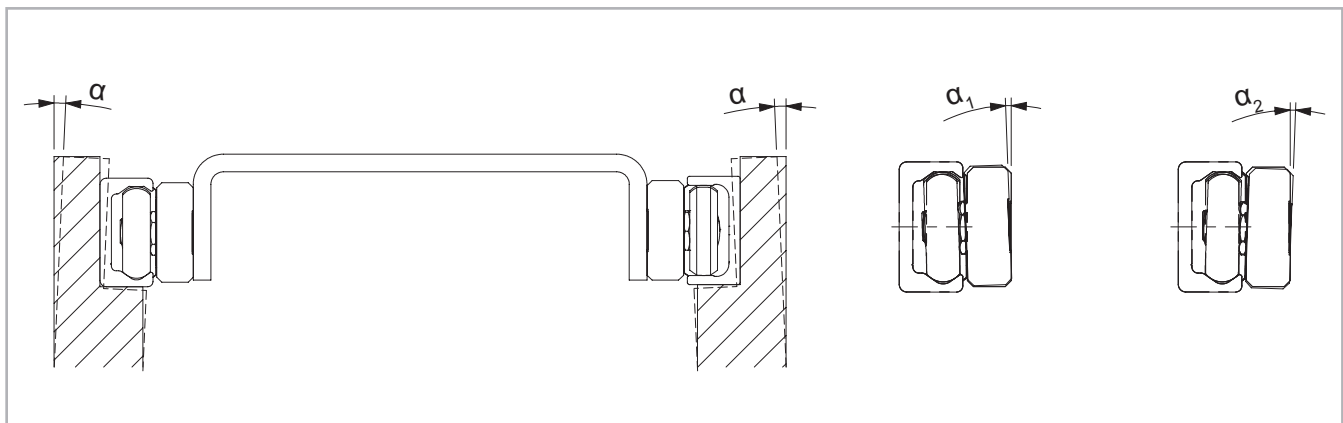

Fig. 137

K+U-system maximum offset

It must be noted that the slider in the U-rail will turn during the movement and rotation of the slider in the K-rail to allow an axial offset. During the combined effect of these movements, you must not exceed the maximum values (see tab. 63). If a maximum rotated NSW or CSW- slider is observed (2° for size 43 and 1° for size 63), the maximum and minimum position of the slider in the U rail results from the values B_{0max} and B_{0min} , which are already considered by the additional rotation caused axial offset. B_{0nom} is a recommended nominal starting value for the position of a NSW or CSW-slider in the U-rail of a K+U-system.

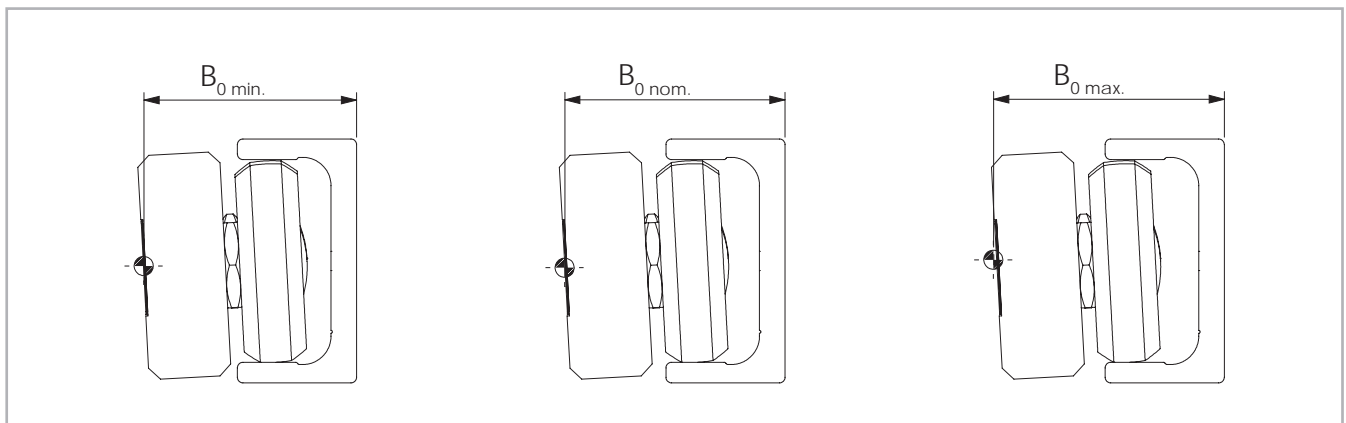

Fig. 138

Slider type	B_{0min} [mm]	B_{0nom} [mm]	B_{0max} [mm]
RLO43	37.6	38.85	40.1
RLP43	37.9	39.15	40.4
RLO63	49.85	51.80	53.75
R...S43	37.6	38.85	40.1
R...S63	49.85	51.80	53.75

Tab. 63

If a K-rail is used in combination with a U-rail, with guaranteed problem-free running and without extreme slider load, a pronounced height difference between the two rails can also be compensated for. The following illustration shows the maximum height offset b of the mounting surfaces in relation to the distance a of the rails (see fig. 139).

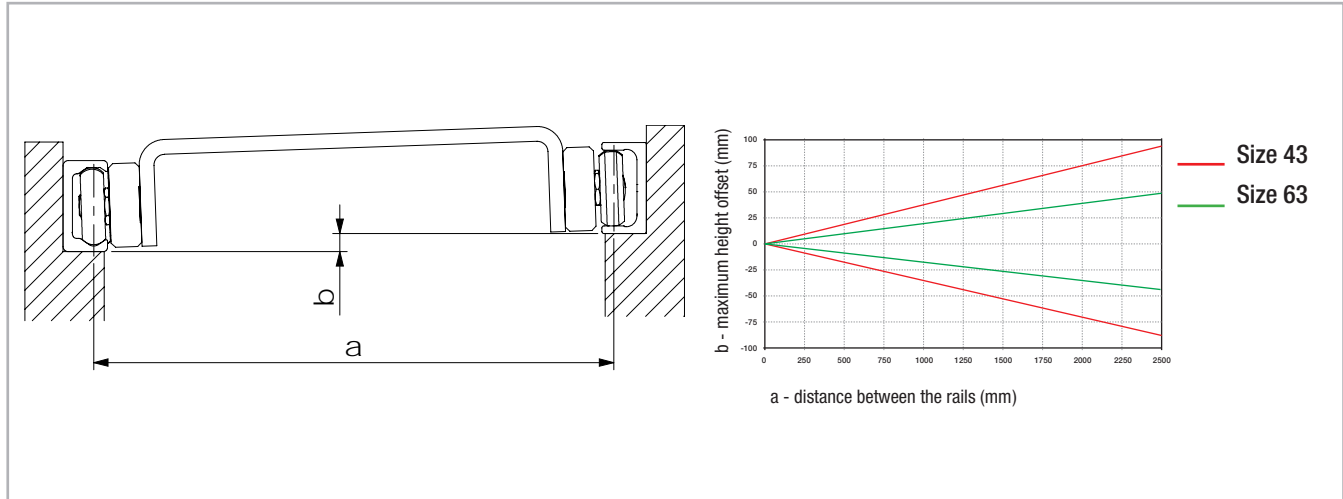

Fig. 139

Even the K+U-system can be used in different arrangements. If the same example as with the F+L-system is observed (see pg. CR-79, fig. 135), this solution, in addition to the prevention of vibrations and moments, also enables the compensation of larger deviations in parallelism in the vertical direction, without negative consequences to the guide. This is particularly important for longer strokes as it is more difficult to obtain a correct vertical parallelism.



Fig. 140

> Preload

Preload classes

The factory installed systems, consisting of rails and sliders, are available in two preload classes:

Standard preload K1 means a rail-slider combination with minimum preload which means the rollers are adjusted free of clearance for optimal running properties.

Usually preload K2 is used for rail-slider systems for increasing the rigidity. When using a system with K2 preload a reduction of the loading capacities and service life must be taken into consideration (see tab. 64).

Preload class	Reduction y
K1	-
K2	0.1

Tab. 64

This coefficient y is used in the calculation formula for checking the static load and lifetime (see pg. CR-101, fig. 177 and pg. CR 105, fig. 194).

The interference is the difference between the contact lines of the rollers and the raceways of the rail.

Preload class	Interference* [mm]	Rail type
K1	0.01	all
K2	0.03	F, L...18
	0.04	F, L...28
	0.05	F, L...35
	0.06	F, L, K...43, F, L, K...63

* Measured on the largest interior dimension between the raceways

Tab. 65

External preload

The unique design of the Compact Rail product family enables applying a partial external preload on selected locations along the entire guide.

An external preload can be applied by pressure along the side surfaces of the guide rail according to the drawing below (see fig. 141). This local preload results in higher rigidity only at the locations where it is necessary (e.g. on reversing points with high dynamic auxiliary forces).

This partial preload increases the service life of the linear guide by

avoiding a continually increased preload over the entire length of the guide. Also the required drive force of the linear carriage in the non-preloaded areas is reduced.

The amount of the externally applied preload is determined using two dial indicators by measuring the deformation of the rail sides. These are deformed by thrust blocks with pressure screws. The external preload must be applied when the slider is not directly located in the pressure zone.

Size	A [mm]
18	40
28	55
35	75
43	80
63	120

Tab. 66

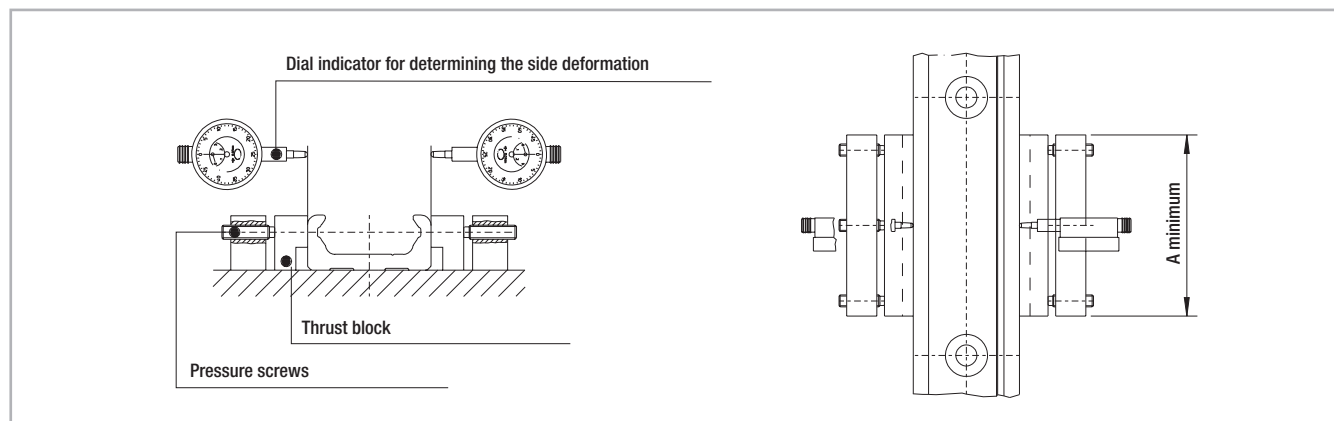

Fig. 141

The graph below indicates the value of the equivalent load as a function of the total deformation of both rail sides. The data relates to sliders with three rollers (see fig. 142).

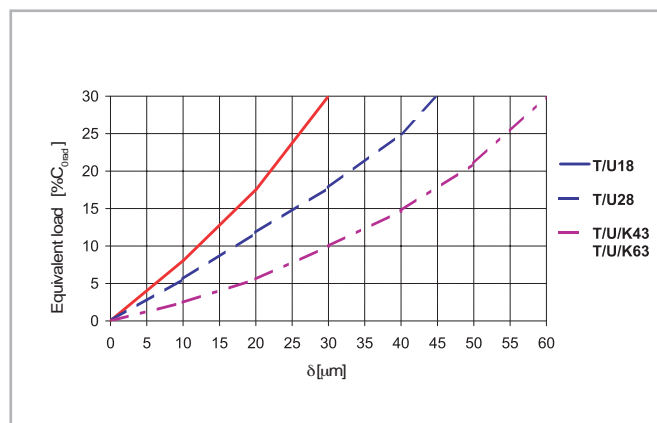

Fig. 142

> Drive force

Frictional resistance

The drive force required for moving the slider is determined by the combined resistance of the rollers, wipers and seals.

The ground raceways and rollers have a minimal coefficient of friction, which remains almost the same in both the static and dynamic state. The wiper and longitudinal seals are designed for an optimum protection of the system, without a significant negative influence on the quality of motion. The overall friction of the Compact Rail also depends on external factors such as lubrication, preload and additional forces. Table 67 below contains the coefficients of friction for each slider type.



Fig. 143

Size	μ Roller friction	μ_w Wiper friction	μ_s Friction of longitudinal seals
18	0.003	$\frac{\ln(m \cdot 1000)^*}{0.98 \cdot m \cdot 1000}$	0.0015
28	0.003	$\frac{\ln(m \cdot 1000)^*}{0.06 \cdot m \cdot 1000}$	$\frac{\ln(m \cdot 1000)^*}{0.15 \cdot m \cdot 1000}$
35	0.005		
43	0.005		
63	0.006		

* Kilograms must be used for load m

Tab. 67

The values given in table 67 apply to external loads, which, with sliders with three rollers, are at least 10 % of the maximum load rating. For calculating the driving force for lower loads, please contact Rollon technical support.

Calculation of drive force

The minimum required drive force for the slider is determined with the coefficients of friction (see tab. 67) and the following formula (see fig. 143):

$$F = (\mu + \mu_w + \mu_s) \cdot m \cdot g$$

$m = \text{mass (kg)}$
 $g = 9.81 \text{ m/s}^2$

Fig. 144

Example calculation:

If a NSW43 slider is used with a radial load of 100 kg, the result is $\mu = 0.005$; from the formula the following is calculated:

$$\mu_s = \frac{\ln(100000)}{0.15 \cdot 100000} = 0.00076$$

$$\mu_w = \frac{\ln(100000)}{0.06 \cdot 100000} = 0.0019$$

Fig. 145

This is the minimum drive force for this example:

$$F = (0.005 + 0.0019 + 0.00076) \cdot 100 \cdot 9.81 = 7.51 \text{ N}$$

Fig. 146

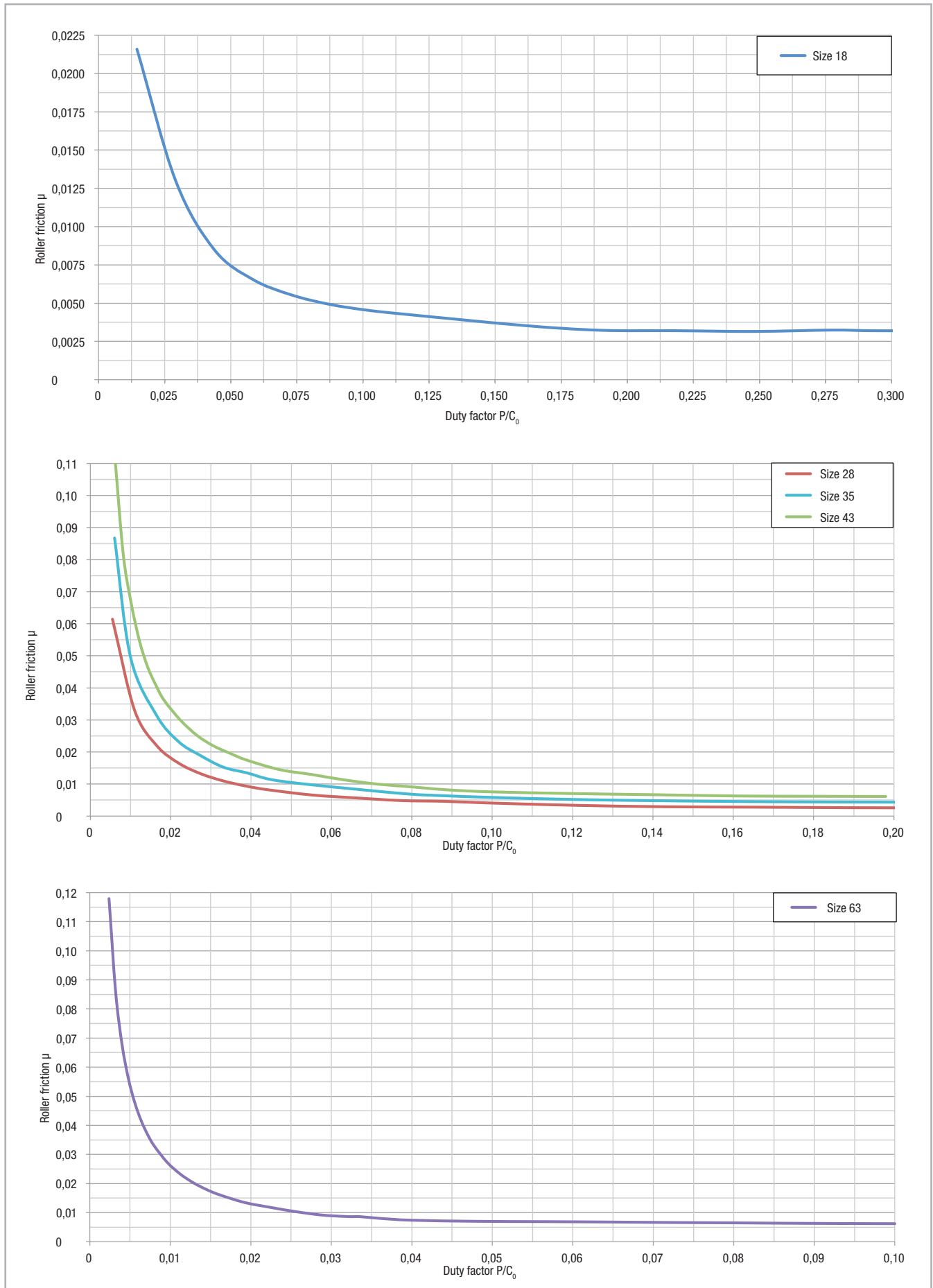

Fig. 147

> Lubrication

Roller pin lubrication

The bearings inside the rollers are lubricated for life. To reach the calculated service life (see pg. CR-105), a film of lubricant should always be

present between the raceway and roller, this also serves to protect against corrosion of the ground raceways.

Lubrication of the raceways

Proper lubrication during normal conditions:

- reduces friction
- reduces wear
- reduces the load of the contact surfaces through elastic deformations
- reduces running noise

> NSW-slider lubrication

The NSW sliders are equipped with wiper heads that include lubricated felts which slowly release oil on the raceways for a long time. The wiper heads can be recharged from the front through a dedicated access hole by means of an oiling syringe.



Fig. 148

The durability of the lubrication delivered by the wiper heads depends on the conditions of use. In the normal clean indoor applications, it is suggested to refill the oil every 0.5 million of cycles, 1000 km or 1 year of use, based on the value reached first. In different conditions, it could be necessary to refill more often, depending on the level of environment criticality. In case of severe dust and dirt conditions, it is suggested to change the entire wiper head with a new one.

When refilling the oil or the substituting the wiper heads, it is recommended to clean the raceways of the guide.

Lubricant	Thickening agent	Temperature range [°C]	Kinematic viscosity 40°C [mm ² /s]
Mineral oil	Lithium soap	-20... to +120	approx 110

Tab. 68

> R...S-slider lubrication

Lubrication when using C-sliders

The CSW series sliders can be provided with wipers made of polyamide to remove contaminants on the raceways. Since the sliders do not have a self-lubrication kit, manual lubrication of the raceways is required. A

guideline is to lubricate the raceways every 100 km or every 6 months. We recommend a roller bearing lubricant with a lithium base of average consistency (see tab. 69).

Lubricant	Thickening agent	Temperature range [°C]	Kinematic viscosity 40°C [mm ² /s]
Roller bearing lubricant	Lithium soap	-20 to +170	approx 160

Tab. 69

Different lubricants are available on request for special applications:

- FDA-approved lubricant for use in the food industry
- specific lubricant for clean rooms

- specific lubricant for the marine technology sector
- specific lubricant for high and low temperatures

For specific information, contact Rollon technical support.

> Corrosion protection

All rails and slider bodies have a standard corrosion protection system by means of electrolytic-zinc plating according to ISO 2081. If increased corrosion protection is required, application-specific surface treatments are available upon request for rails and slider bodies e.g. approved nickel

plated for use in the food industry. In this case, the chosen treatment must be specified in the order for both rails and sliders using the appropriate code shown in the table below. For more information contact Rollon technical support.

Treatment	Characteristics
Zinc Plating ISO 2081	Standard treatment for all sizes of rails and slider bodies, it is ideal for indoor applications. When applied to the rail, it is removed from the raceways by the subsequent grinding process. Zinc-plated sliders are supplied with steel rollers.
Rollon Alloy (Y)	Electrolytic plating with high resistance passivation, ideal for outdoor applications. When applied to the rail, it is removed from the raceways by the subsequent grinding process. Sliders ordered with Rollon Alloy treatment are supplied with stainless steel rollers to further increase the corrosion resistance.
Rollon E-coating (K)	As zinc-plated version with additional electro painting that provides a fine black finishing to the entire rail. When applied to the rail, the slider can partially remove the coating from the raceways on the running contact point after a period of use. Sliders ordered with Rollon E-Coating are supplied with stainless steel rollers to further increase the corrosion resistance.
Nickel Plating (N)	Provides high resistance to chemical corrosion and is ideal for applications in medical or food related environments. When applied to the rail, raceways are coated too. Sliders ordered with Nickel Plating treatment are supplied with stainless steel rollers to further increase the corrosion resistance.

Tab. 70

> Speed and acceleration

The Compact Rail product family is suitable for high operating speeds and accelerations.

Size	Speed [m/s]	Acceleration [m/s ²]
18	3	10
28	5	15
35	6	15
43	7	15
63	9	20

Tab. 71

> Operating temperatures

The temperature range for continuous operation is: -20 °C / +120 °C with occasional peaks up to +150 °C.

Installation instructions

> Fixing holes

V-holes with 90° bevels

The selection of rails with 90° countersunk holes is based on the precise alignment of the threaded holes for installation. Here the complex alignment of the rail to an external reference is omitted, since the rail aligns during installation by the self-centering of the countersunk screws on the existing hole pattern.

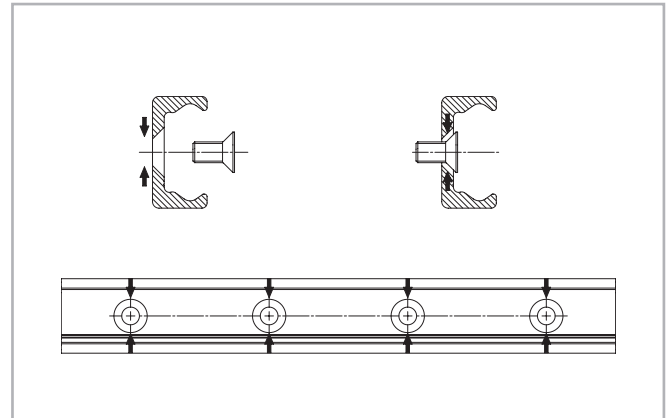

Fig. 149

C-holes with cylindrical counterbore

When a rail with counterbored holes is delivered, the Torx® screws are provided in the right quantity. The cylindrical screw has, as shown, some play in the countersunk fixing hole, so that an optimum alignment of the rail can be achieved during installation (see fig. 150).

The area T is the diameter of the possible offset, in which the screw center point can move during the precise alignment.

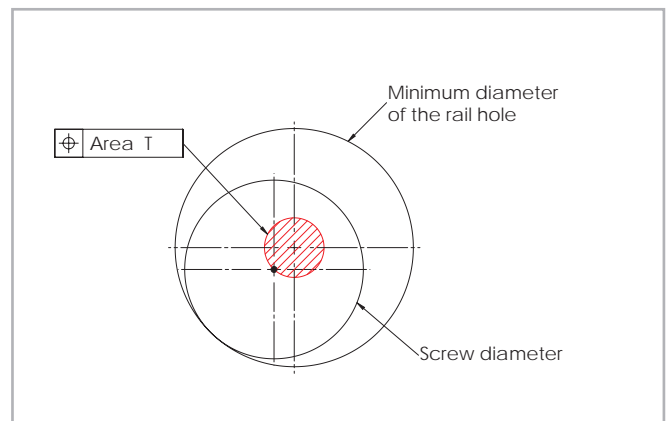

Fig. 150

Rail type	Area T [mm]
FRZ18 - LRZ18	∅ 1.0
FRZ28 - LRZ28	∅ 1.0
FRZ35 - LRZ35	∅ 1.5
FRZ43 - LRZ43 - KRZ43	∅ 2.0
FRZ63 - LRZ63 - KRZ63	∅ 0.5

Tab. 72

Chamfers

Chamfers must be realized for both C-holes and V-holes rails. The minimum chamfers on the fixing threads are listed on the table below.

Size	Chamfer C-holes [mm]	Chamfer V-holes [mm]
18	0.5 x 45°	0.5 x 45°
28	0.6 x 45°	1 x 45°
35	0.5 x 45°	1 x 45°
43	1 x 45°	1 x 45°
63	0.5 x 45°	1 x 45°

Tab. 73

Example for fixing with Torx® screws (custom design)

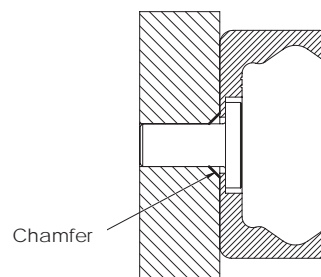

Example for fixing with countersunk screws

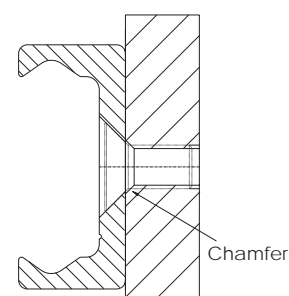

Fig. 151

> Adjusting the sliders

Normally the linear guides are delivered as a system consisting of rail and adjusted sliders. If rail and slider are delivered separately or if the slider is installed in another raceway, the preload must be set again.

Setting the preload:

- (1) Verify that the raceways are clean and take the wipers off to obtain a more sensitive feeling for correct preload setting.
- (2) Insert the slider in the rail. Slightly loosen the fixing screws of the roller pins (no marking) to be adjusted.
- (3) Position the slider on one end of the rail.
- (4) For the U rails there must be a thin support (e.g. set key) under the ends of the slider body to ensure the horizontal alignment of the slider in the flat raceways.
- (5) Insert the included special flat wrench from the side between the rail and the slider. Take care to insert it from one end of the slider, slip it under the lateral sealing and then slide it until the eccentric roller to be adjusted is reached.



Fig. 152

- (6) By turning the flat key clockwise, the roller to be adjusted is pressed against the upper track and the slider is then without play. Avoid a preload that is too high. It generates increased wear and reduces the service life.
- (7) While holding the correct position of the roller with the adjustment key, the fixing screw can be carefully tightened. The exact tightening torque will be checked later (see fig. 152 and tab. 74).
- (8) Move the slider in the rail and check the preload over the entire length of the rail. It should move easily and the slider should not have play at any location of the rail.
- (9) For sliders with more than 3 rollers, repeat this process with each eccentric roller. Make sure that all rollers have even contact to the tracks.
- (10) Now tighten the fixing screws with the specified tightening torque from the table while the flat key holds the angle adjustment of the pin. A special thread in the roller pin secures the set position.
- (11) Ensure proper lubrication of the raceways.

Slider size	Tightening torque [Nm]
18	3
28	7
35	7
43	12
63	35

Tab. 74

> Use of radial ball bearing rollers

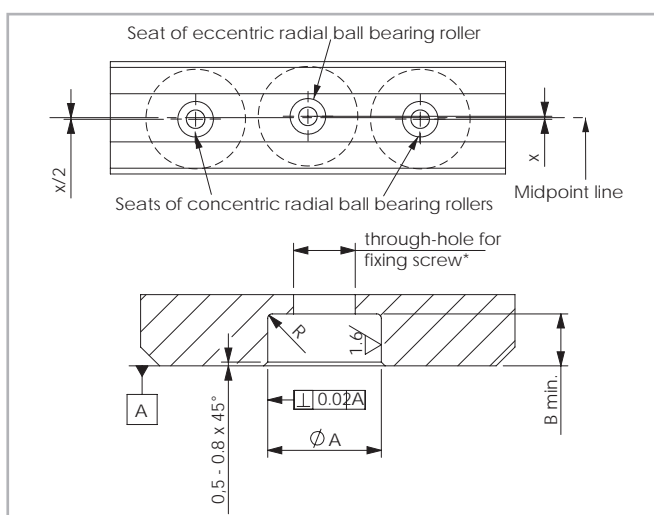

Fig. 153

If purchasing "Radial ball bearing rollers" to install on your own structure (see p. CR-72) we advise:

- Using a maximum of 2 concentric radial ball bearing rollers
- Offset the seats of the concentric radial ball bearing rollers with respect to those of the eccentric radial ball bearing rollers according to the table (tab. 75).

Slider size	X [mm]	Ø A [mm]	B min. [mm]	Radius R [mm]
18	0.30	6 + 0.025/+0.01	2.1	0.5
28	0.64	10 + 0.03/+0.01	4.0	0.5
35	0.90	12 + 0.05/+0.02	4.5	0.5
43	0.72	12 + 0.05/+0.02	5.5	1
63	0.55	18 + 0.02/-0.02	7	1

Tab. 75

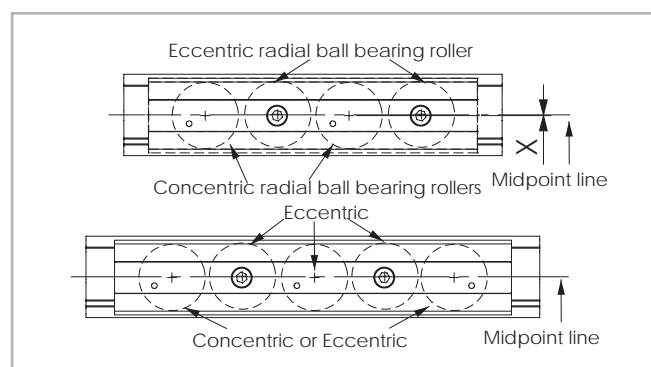

Fig. 154

> Installing the single rail

The T- and K-rails can be installed in two positions relative to the external force. For axial loading of the slider (fig. 155. pos. 2), the load capacity is reduced because of the decline in contact area caused by the change in position. Therefore, the rails should be installed in such a way that the load on the rollers acts in the radial direction (fig. 155, pos. 1). The number of fixing holes in the rail in combination with screws of property class 10.9 is dimensioned in accordance with the load capacity values. For critical applications with vibrations or higher demand for rigidity, a support of the rail (fig. 155, pos. 3) is advantageous.

This reduces deformation of the sides and the load on the screws. The installation of a rail with countersunk holes requires an external reference for alignment. This reference can also be used simultaneously as rail support if required. All information in this section on alignment of the rails, refers to rails with counterbored holes. Rails with countersunk holes self-align using the specified fixing hole pattern (see pg. CR-89, fig. 149).

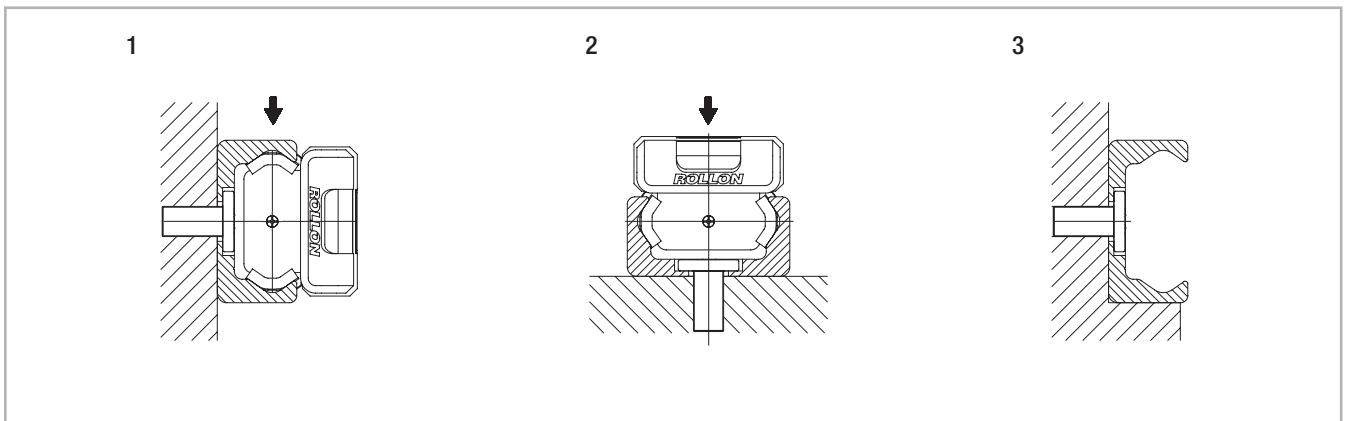

Fig. 155

Rail installation with reference surface as support

- (1) Remove unevenness, burrs and dirt from the support surface.
- (2) Press the rail against the support surface and insert all screws without tightening them.
- (3) Start tightening the fixing screws to the specified torque on one end of the rail while continuing to hold pressure on the rail against the support surface.

Screw type	Torx® tightening torque [Nm]	Countersunk tightening torque [Nm]
M4 (T..., U... 18)	3	3
M5 (T..., U... 28)	9	6
M6 (T..., U... 35)	12	10
M8 (T..., U..., K... 43)	22	25
M8 (T..., U..., K... 63)	35	30

Tab. 76

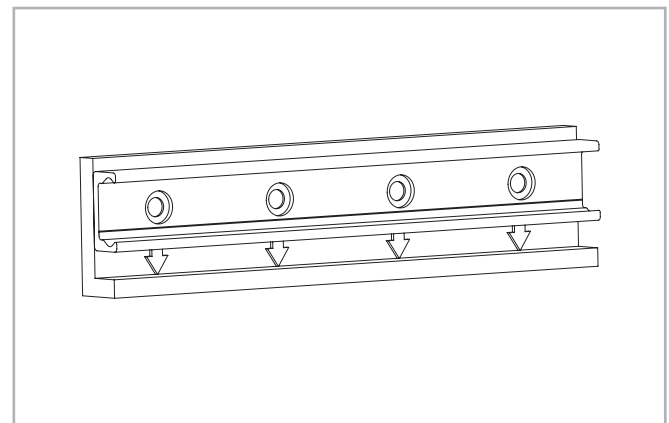

Fig. 156

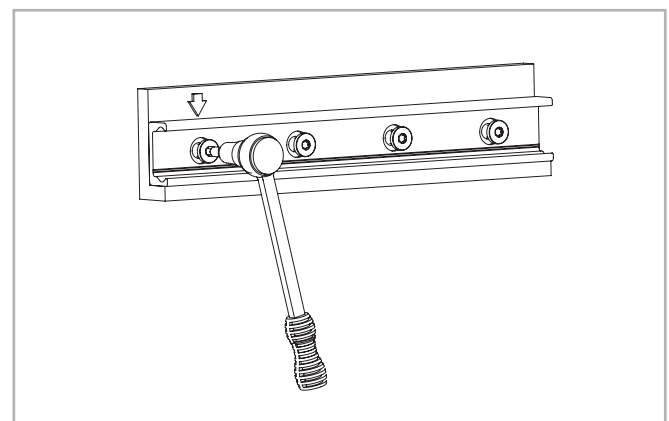

Fig. 157

Rail installation without support

(1) Carefully lay the guide rail with installed slider on the mounting surface and slightly tighten the fixing screws so that the guide rail lightly touches the mounting surface.

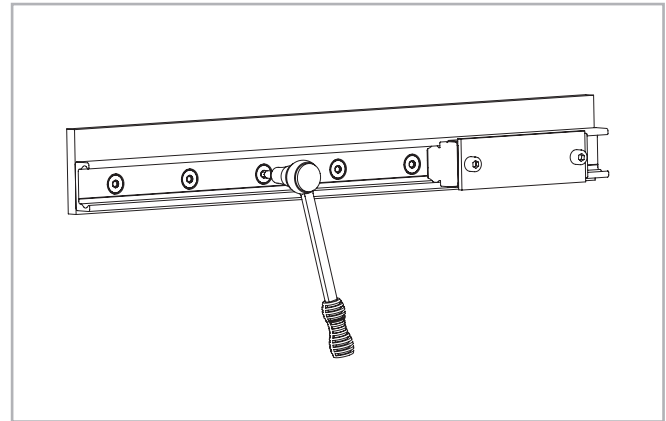

Fig. 158

(2) Install a dial indicator so that the offset of the rail to a reference line can be measured. Now position the slider in the center of the rail and set the dial indicator to zero. Move the slider back and forth between each two hole spacings and carefully align the rail. Fasten the three center screws of this area now with the the specified tightening torque, see pg. fig. 159.
 (3) Now position the slider on one end of the rail and carefully align the rail to zero on the dial indicator.

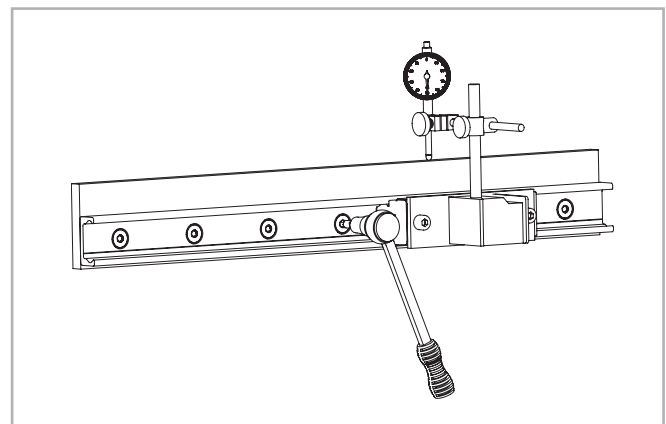

Fig. 159

(4) Begin to tighten the screws as specified while moving the slider together with the dial indicator. Make sure that it does not show any significant deflection. Repeat this procedure from the other end of the rail.

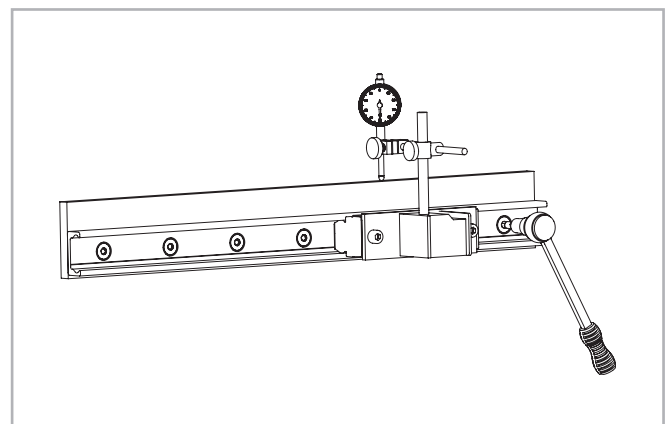

Fig. 160

> Parallel installation of two rails

If two T-rails or a F+L-system are installed, the height difference of the two rails must not exceed a certain value (obtainable from the table below) in order to ensure proper guiding. These maximum values result from the maximum allowable twisting angle of the rollers in the raceways (see tab. 77). These values account for a load capacity reduction of 30% on the T-rail and must absolutely be maintained in every case.

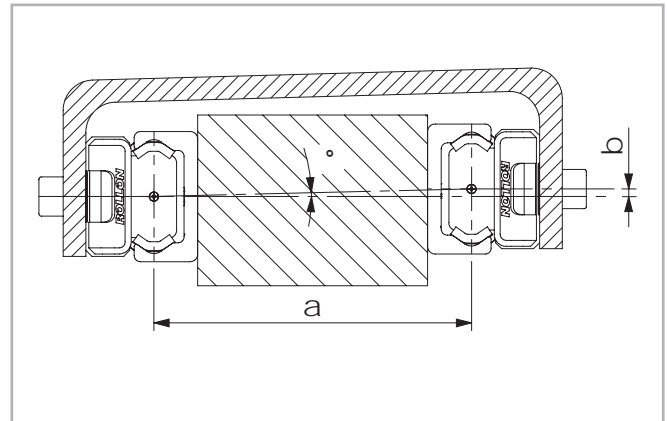

Fig. 161

Size	α
18	1 mrad (0.057°)
28	2.5 mrad (0.143°)
35	2.6 mrad (0.149°)
43	3 mrad (0.171°)
63	5 mrad (0.286°)

Tab. 77

Example:

NSW43: if $a = 500 \text{ mm}$; $b = a \cdot \tan \alpha = 1.5 \text{ mm}$

When using two T-rails, the maximum parallelism deviation must not be exceeded (see tab. 78). Otherwise stresses can occur, which can result in a reduction in load capacity and service life.

Rail size	K1	K2
18	0.03	0.02
28	0.04	0.03
35	0.04	0.03
43	0.05	0.04
63	0.06	0.05

Tab. 78

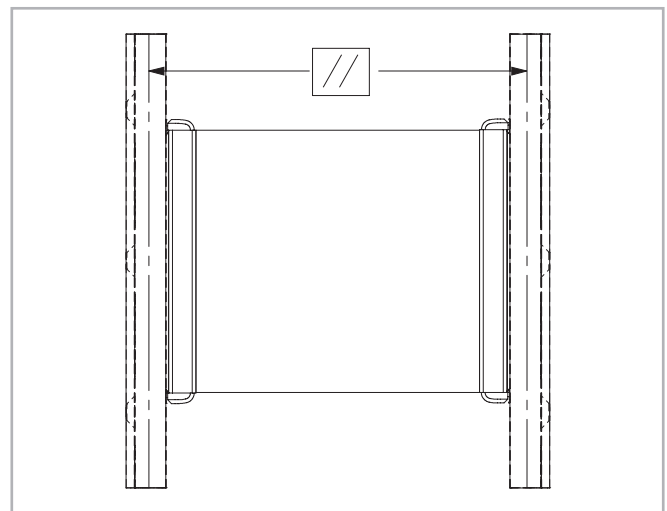

Fig. 162

Note: For parallelism problems, it is recommended to use a F+L or K+U system, since these combinations compensate for inaccuracies (see pg. CR-78 and following).

Parallel installation of two T-rails

(1) Clean chips and dirt from the prepared mounting surfaces and fasten the first rail as described in the section on installation of a single rail.

(2) Fasten the second rail on the ends and the center. Tighten the screws in Position A and measure the distance between the raceways of the two rails.

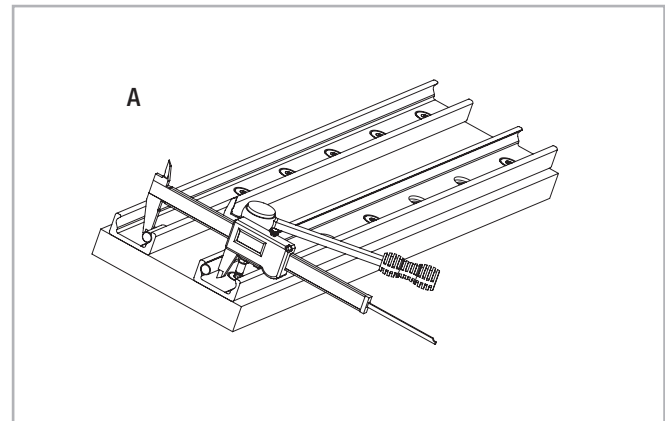

Fig. 163

(3) Fasten the rail in Position B so that the distance between the raceways does not exceed the measured values in Position A while maintaining the tolerances (see pg. CR-93, tab. 78) for parallel rail installation.

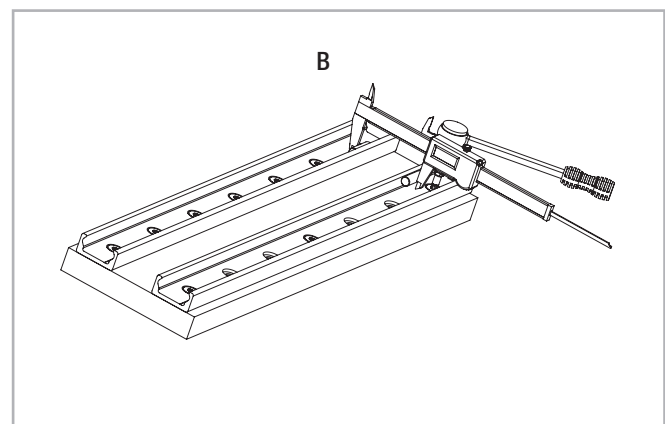

Fig. 164

(4) Fasten the screw in Position C so that the distance of the raceways is as close to an average between the two values from A and B as possible.

(5) Fasten all other screws and check the specified tightening torque of all fixing screws (see pg. CR-91, tab. 76).

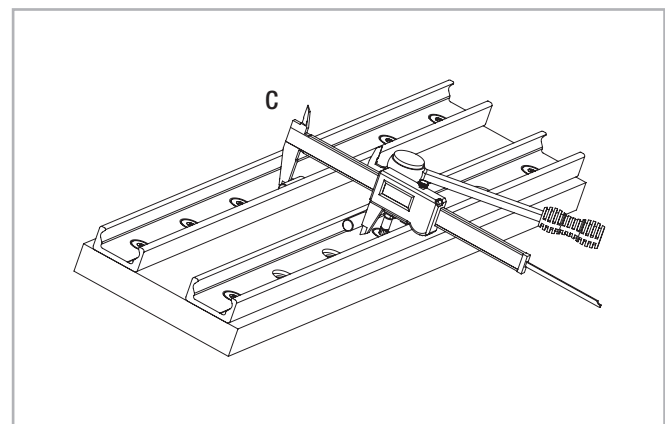

Fig. 165

> Installation of the F+L- or the K+U-system

When using a two-track parallel linear guide we recommend the use of a fixed bearing / compensating bearing system: The combination of T+U-rails for compensation of deviations in parallelism or the K+U-system to compensate for deviations in parallelism in two planes.

Installation steps

(1) For a fixed bearing / compensating bearing system the fixed bearing rail is always installed first. This is then used as a reference for the compensating bearing rail.

Then proceed as described in the section on installation of a single rail (see pg. CR-93).

(2) Install the compensating bearing rail and only tighten the fixing screws slightly.

(3) Insert the sliders in the rails and install the element to be moved, without tightening its screws.

(4) Insert the element in the center of the rails and tighten it, use screws class 10.9.

(5) Tighten the center rail fixing screws to the specified torque (see pg. CR-91, tab. 76).

(6) Move the element to one end of the rail and start tightening the rest of the screws in the direction away from the slider.

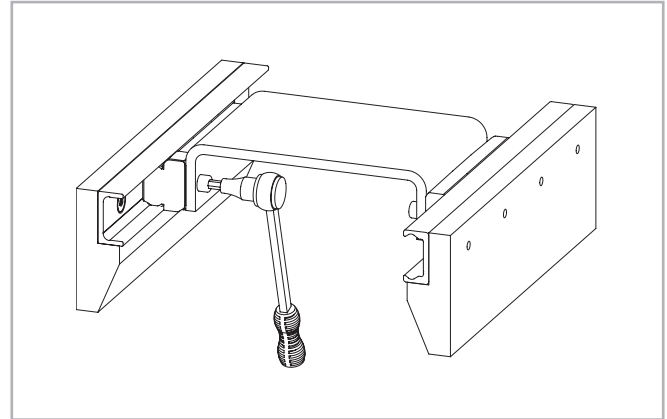

Fig. 166

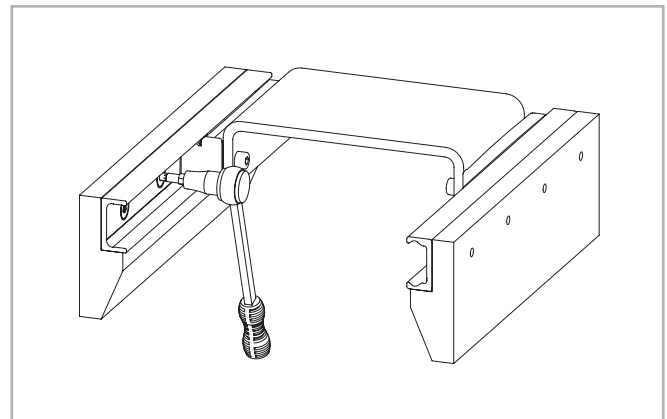

Fig. 167

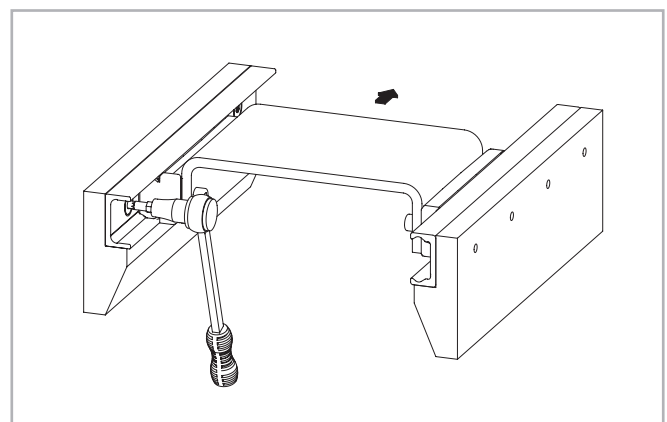

Fig. 168

> Joined Rails

If long guide rails are required, two or more rails can be joined to the desired length. When putting guide rails together, be sure that the register marks shown in fig. 169 are positioned correctly.

For applications with parallel joined guide rails we suggest them to be fabricated asymmetric.

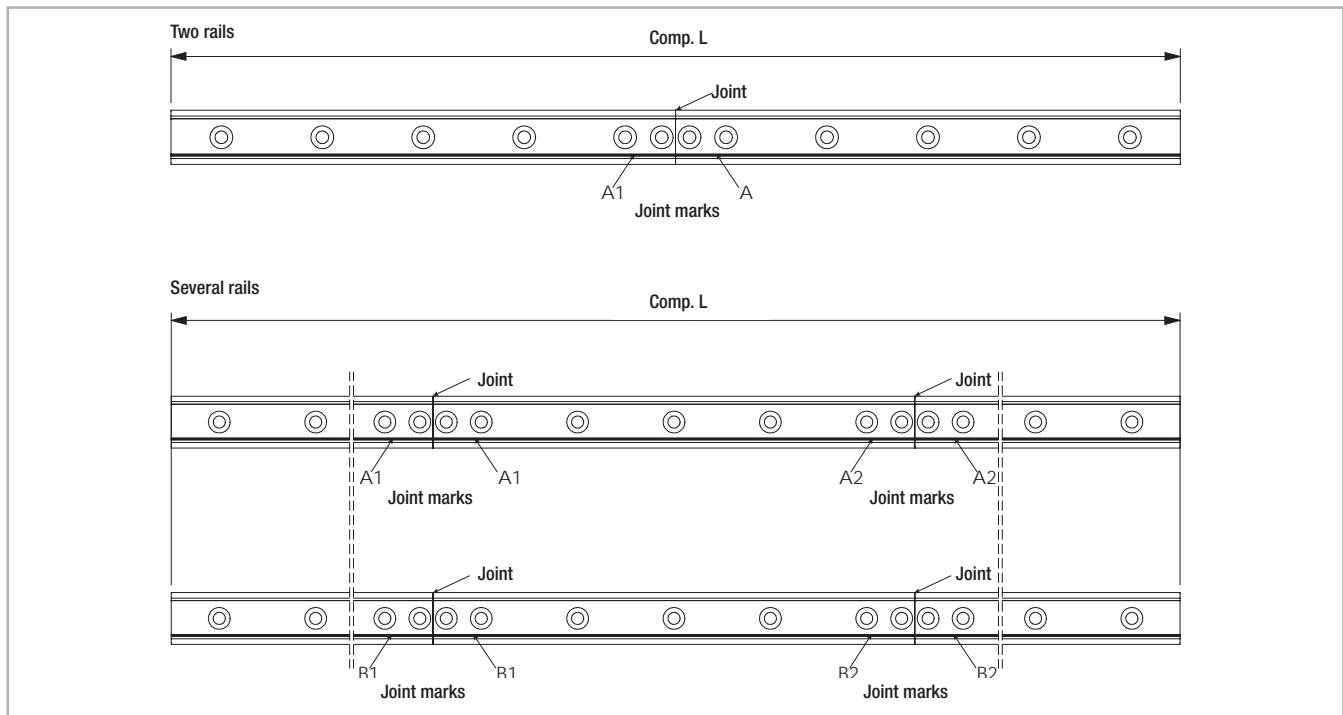

Fig. 169

General information

The maximum available rail length in one piece is indicated in table 40 on page CR-59. Longer lengths are achieved by joining two or more rails (joined rails).

Rollon then machines the rail ends at a right angle to the impact surfaces and marks them. Additional fixing screws are included with the delivery, which ensure a problem-free transition of the slider over the joints, if the following installation procedures are followed. Two additional threaded holes (see fig. 170) are required in the load-bearing structure. The included end fixing screws correspond to the installation screws for the rails for cylindrical counterbores (see pg. CR-89).

The alignment fixture for aligning the rail joint can be ordered using the designation given in the table (see pg. CR-73, tab. 53 and 54).

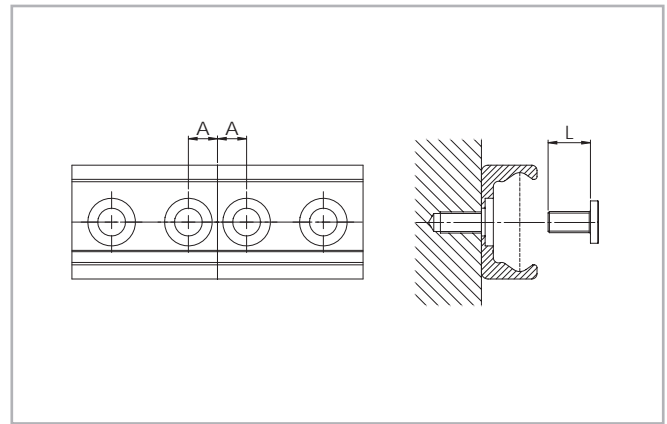

Fig. 170

Rail type	A [mm]	Threaded hole (load-bearing structure)	Screw type	L [mm]	Alignment fixture
F..., L...18	7	M4	see pg. CR-89	8	AT18
F..., L...28	8	M5		10	AT28
F..., L...35	10	M6		13	AT35
F..., L...43	11	M8		16	AT43
F..., L...63	8	M8		20	AT63
K...43	11	M8		16	AK43
K...63	8	M8		20	AK63

Tab. 79

> Installation of joined rails

After the fixing holes for the rails are made in the load-bearing structure, the joined rails can be installed according to the following procedure:

- (1) Fix the individual rails on the mounting surface by tightening all screws except for each last one on the rail joint.
- (2) Install the end fixing screws without tightening them (see fig. 171).

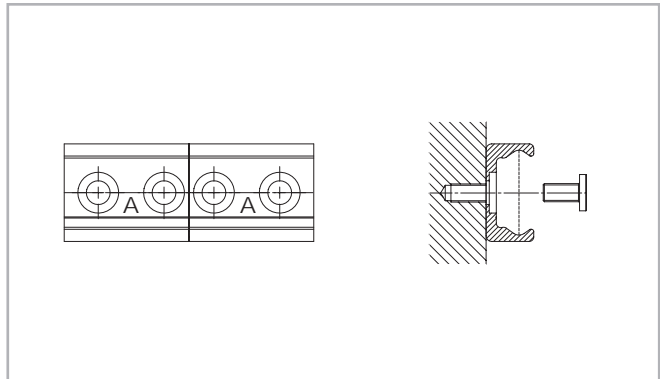

Fig. 171

- (3) Place the alignment fixture on the rail joint and tighten both set screws uniformly, until the raceways are aligned (see fig. 172).
- (4) After the previous step (3) it must be checked if both rail backs lie evenly on the mounting surface. If a gap has formed there, this must be shimmed.

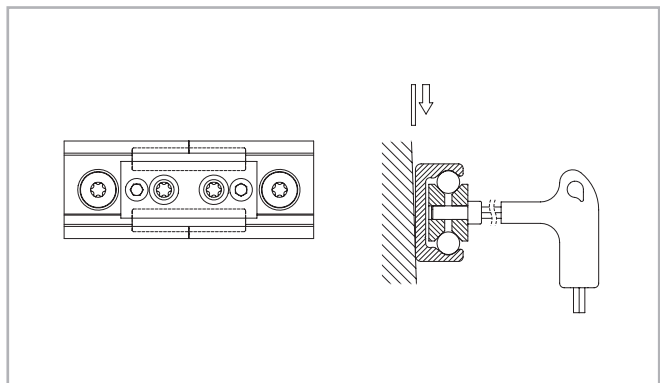

Fig. 172

- (5) The bottom of the rails should be supported in the area of the transition. Here a possible existing gap must be looked for, which must be closed for correct support of the rail ends by shims.

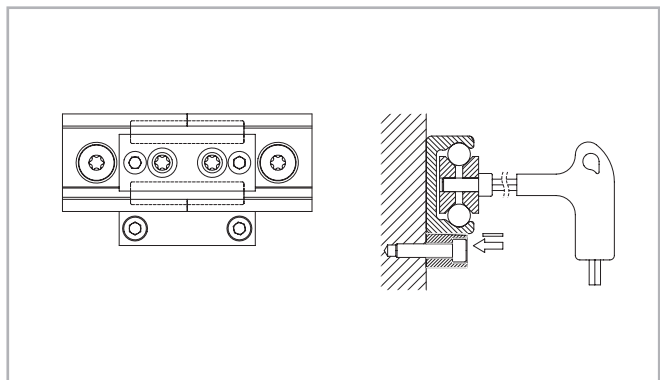

Fig. 173

- (6) Insert the key through the holes in the alignment fixture and tighten the screws on the rail ends.
- (7) For rails with 90° countersunk holes, tighten the remaining screws starting from the rail joint in the direction of the rail center. For rails with cylindrical counter-sunk holes, first adjust the rail to an external reference, then proceed as described above.
- (8) Remove the alignment fixture from the rail.

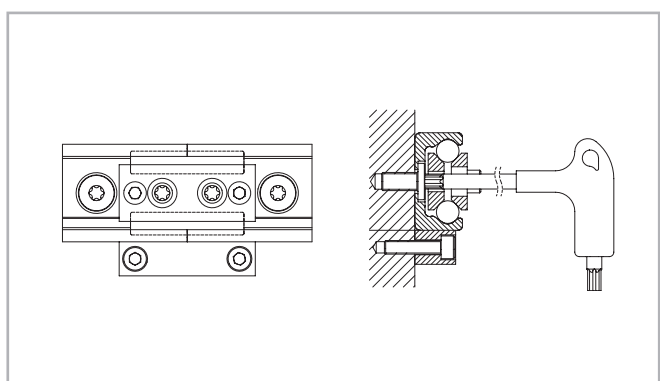

Fig. 174

Ordering key



> Rail / slider system

FRZ28	-4560	/2/	RFO	28	-4	B	-2Z	-N
								Expanded surface protection if deviation from Standard ISO 2081 <i>see pg. CR-88, tab.70</i>
							Roller seal	<i>see pg. CR-72</i>
							Configuration depending on type of slider <i>see pg. CR-60 and CR-67</i>	
							Number of rollers	<i>see pg. CR-60 and CR-67</i>
							Size	<i>see pg. CR-60 and CR-67</i>
							Slider type	<i>see pg. CR-60 and CR-67</i>
							Number of sliders in one rail	
							Rail length in mm	<i>see pg. CR-59, tab. 40</i>
							Rail type	<i>see pg. CR-59, tab. 39</i>

Ordering example: FRZ28-4560/2/RFO28-4B-2Z-N

Rail composition: 1x3280+1x1280 (only for joint processed rails)

Hole pattern: 40-40x80-40//40-15x80-40 (please always specify the hole pattern separately)

Notes on ordering: The rail length codes are always 5 digits, the slider length codes are always 3 digits; use zeroes as a prefix when lengths are shorter

> Rail

FRS	43	-5680	-N
			Expanded surface protection if deviation from Standard ISO 2081 <i>see pg. CR-88, tab.70</i>
			Rail length in mm <i>see pg. CR-59, tab. 40</i>
			Size <i>see pg. CR-59, tab. 39</i>
			Rail type <i>see pg. CR-59, tab. 39</i>

Ordering example: FRS43-5680-N

Rail composition: 1x880+2x2400 (only for joint processed rails)

Hole pattern: 40-10x80-40//40-29x80-40//40-29x80-40 (please always specify the hole pattern separately)

Notes on ordering: The rail length codes are always 5 digits; use zeroes as a prefix when lengths are shorter

> Slider

RFO	28	-4	B	-2RS	-N	
						Expanded surface protection if deviation from Standard ISO 2081 <i>see pg. CR-88, tab.70</i>
				Roller seal		<i>see pg. CR-72</i>
					Configuration depending on type of slider	<i>see pg. CR-60 and CR-67</i>
					Number of rollers	<i>see pg. CR-60 and CR-67</i>
					Size	<i>see pg. CR-60 and CR-67</i>
					Slider type	<i>see pg. CR-60 and CR-67</i>

Ordering example: RFO28-4B-2RS-N

Notes on ordering: The slider length codes are always 3 digits; use zeroes as a prefix when lengths are shorter

> Wipers

ZK-WNS	28	
	Size	<i>see pg. CR-60 and CR-67</i>
	Wiper type	<i>see pg. CR-73, fig. 121, fig.122</i>

Ordering example: ZK-WNS28

Note on ordering: every kit contains a pair of wipers. Two wipers per slider are always required.

Calculation formulas

> Static load

The radial load capacity rating, C_{Orad} , the axial load capacity rating C_{Oax} , and moments M_x, M_y, M_z indicate the maximum permissible values of the load (see from pg. CR-8 to CR-10 and CR-54, CR-57), higher loads will have a detrimental effect on the running quality. A safety factor, S_0 , is used to check the static load, which takes into account the basic parameters of the application and is defined more in detail in the following table:

Safety factor S_0

No shock nor vibration, smooth and low-frequency reverse, high assembly accuracy, no elastic deformations	1 - 1.5
Normal installation conditions	1.5 - 2
Shock and vibration, high-frequency reverse, significant elastic deformation	2 - 3.5

Fig. 175

The ratio of the actual load to maximum permissible load may be as large as the reciprocal of the accepted safety factor, S_0 , at the most.

$\frac{P_{Orad}}{C_{Orad}} \leq \frac{1}{S_0}$	$\frac{P_{Oax}}{C_{Oax}} \leq \frac{1}{S_0}$	$\frac{M_1}{M_x} \leq \frac{1}{S_0}$	$\frac{M_2}{M_y} \leq \frac{1}{S_0}$	$\frac{M_3}{M_z} \leq \frac{1}{S_0}$
--	--	--------------------------------------	--------------------------------------	--------------------------------------

Fig. 176

The above formulas are valid for a single load case.

If two or more forces are acting simultaneously, please check the following formula:

$\frac{P_{Orad}}{C_{Orad}} + \frac{P_{Oax}}{C_{Oax}} + \frac{M_1}{M_x} + \frac{M_2}{M_y} + \frac{M_3}{M_z} + y \leq \frac{1}{S_0}$	<ul style="list-style-type: none"> P_{Orad} = effective radial load (N) C_{Orad} = permissible radial load (N) P_{Oax} = effective axial load (N) C_{Oax} = permissible axial load (N) M_1, M_2, M_3 = external moments (Nm) M_x, M_y, M_z = maximum permissible moments in the different loading directions (Nm) y = reduction due to preload (see pg. CR-29, Tab. 20 or pg. CR-83, Tab. 64)
--	---

Fig. 177

The safety factor S_0 can lie on the lower given limit if the occurring forces can be determined with sufficient precision. If shock and vibration are present, the higher value should be selected. For dynamic applications higher safety is required. Please contact Rollon technical support.

> Slider load

Examples of formulas for determining the forces on the most heavily loaded slider

For an explanation of the parameters in the formulas see pg. CR-104, fig. 192

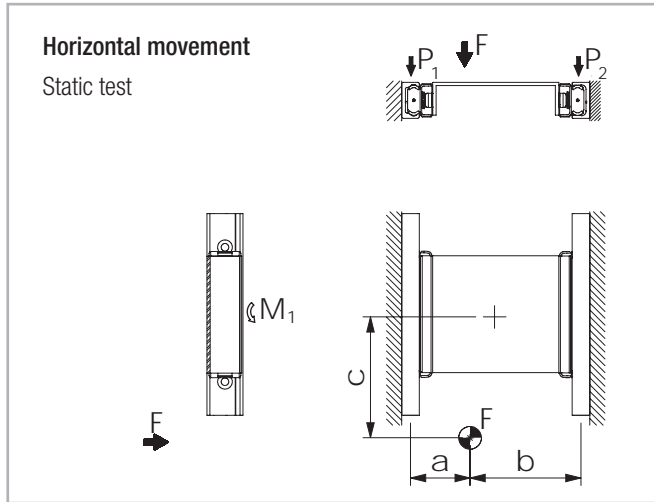

Fig. 178

Slider load:

$$P_1 = F \cdot \frac{b}{a+b}$$

$$P_2 = F - P_1$$

in addition each slider is loaded by a moment:

$$M_1 = \frac{F}{2} \cdot c$$

Fig. 181

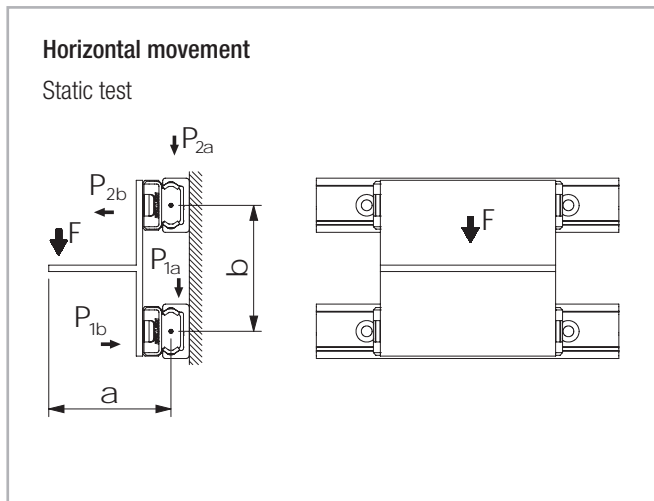

Fig. 179

Slider load:

$$P_{1a} \cong P_{2a} = \frac{F}{2}$$

$$P_{2b} \cong P_{1b} = F \cdot \frac{a}{b}$$

Fig. 182

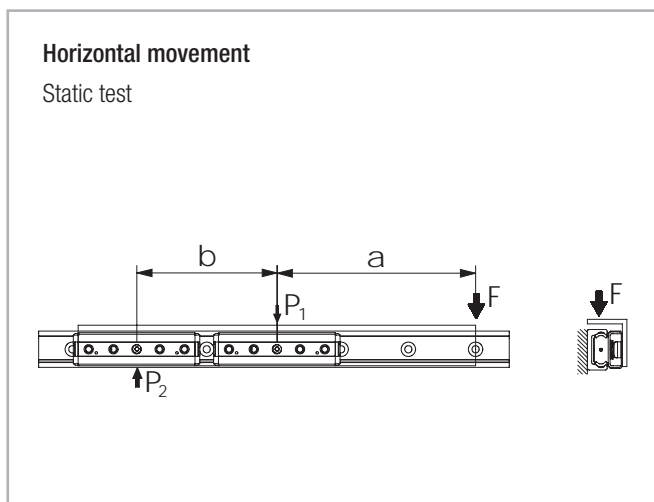

Fig. 180

Slider load:

$$P_2 = F \cdot \frac{a}{b}$$

$$P_1 = P_2 + F$$

Fig. 183

Note: Applies only if the distance between centers of the sliders $b > 2x$ slider length

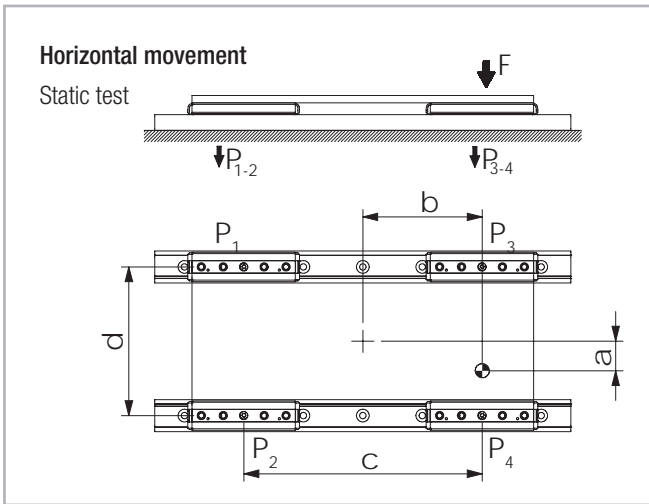

Fig. 184

Slider load:

$$P_1 = \frac{F}{4} - \left(\frac{F}{2} \cdot \frac{b}{c}\right) - \left(\frac{F}{2} \cdot \frac{a}{d}\right)$$

$$P_2 = \frac{F}{4} - \left(\frac{F}{2} \cdot \frac{b}{c}\right) + \left(\frac{F}{2} \cdot \frac{a}{d}\right)$$

$$P_3 = \frac{F}{4} + \left(\frac{F}{2} \cdot \frac{b}{c}\right) - \left(\frac{F}{2} \cdot \frac{a}{d}\right)$$

$$P_4 = \frac{F}{4} + \left(\frac{F}{2} \cdot \frac{b}{c}\right) + \left(\frac{F}{2} \cdot \frac{a}{d}\right)$$

Fig. 187

Note: It is defined that slider no. 4 is always located closest to the point where the force is applied.

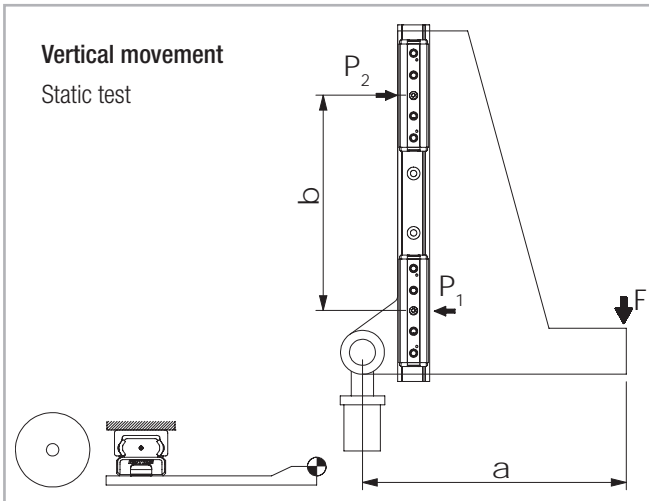

Fig. 185

Slider load:

$$P_1 \cong P_2 = F \cdot \frac{a}{b}$$

Fig. 188

Note: Applies only if the distance between centers of the sliders $b > 2x$ slider length

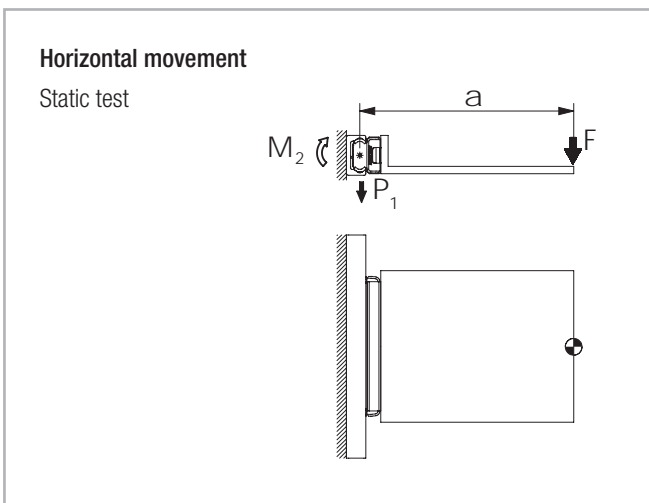

Fig. 186

Slider load:

$$P_1 = F$$

$$M_2 = F \cdot a$$

Fig. 189

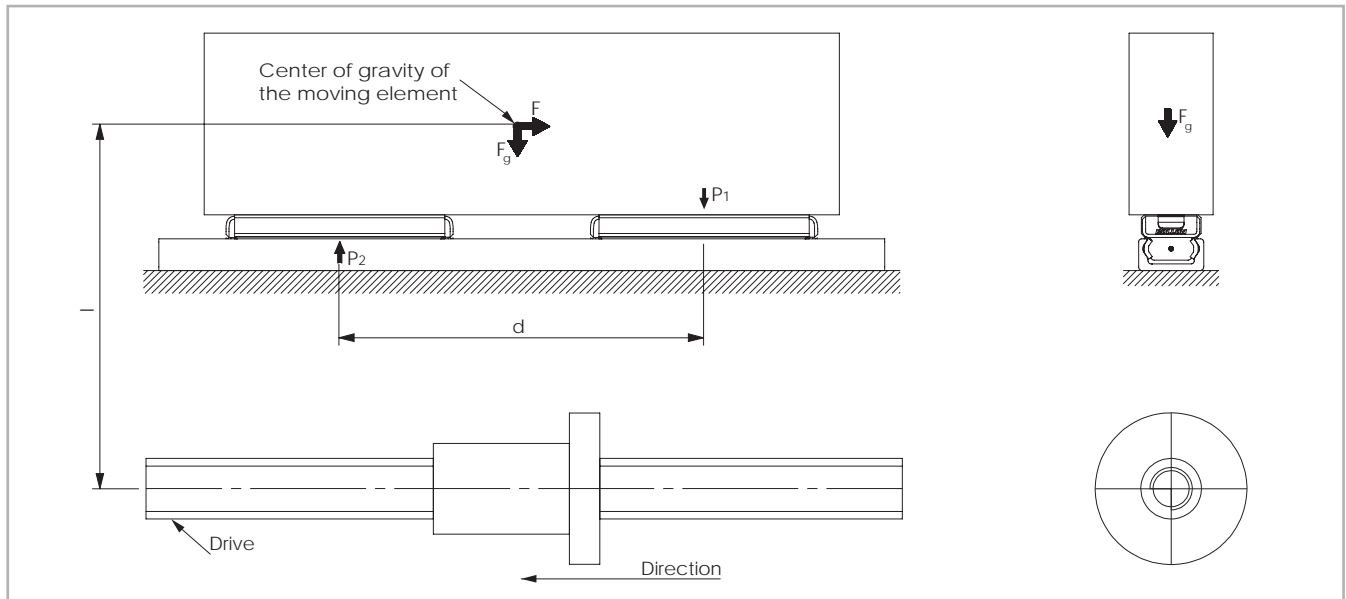

Fig. 190

Horizontal movement

Test with a moving element of the weight-force F_g at the instant the direction of movement changes

Inertial force	Slider load at time of reverse
$F = m \cdot a$	$P_1 = \frac{F \cdot l}{d} + \frac{F_g}{2}$ $P_2 = \frac{F_g}{2} - \frac{F \cdot l}{d}$

Fig. 191

Explanation of the calculation formula

- F = effective force (N)
- F_g = weight-force (N)
- P_1, P_2, P_3, P_4 = effective load on the slider (N)
- M_1, M_2 = effective moment (Nm)
- m = mass (kg)
- a = acceleration (m/s^2)

Fig. 192

> Service life

The dynamic load capacity C is a conventional variable used for calculating the service life. This load corresponds to a nominal service life of 100 km. For values of the individual slider see from pg. CR-8 to CR-10 and CR-54, CR-57. The following formula (see fig. 193) links the calculated theoretical service life to the dynamic load capacity and the equivalent load:

$$L_{km} = 100 \cdot \left(\frac{C}{P} \cdot \frac{f_c}{f_i} \cdot f_h \right)^3$$

L_{km} = theoretical service life (km)
 C = dynamic load capacity (N)
 P = effective equivalent load (N)
 f_c = contact factor
 f_i = application coefficient
 f_h = stroke factor

Fig. 193

The equivalent load P corresponds in its effects to the sum of the forces and moments working simultaneously on a slider. If these different load components are known, P results as follows:

$$P = P_r + \left(\frac{P_a}{C_{0ax}} + \frac{M_1}{M_x} + \frac{M_2}{M_y} + \frac{M_3}{M_z} + y \right) \cdot C_{0rad}$$

y = reduction due to preload
 (see pg. CR-29, Tab. 20 or pg. CR-83, Tab. 64)

Fig. 194

Here the external loads are assumed as constant in time. Brief loads, which do not exceed the maximum load capacities, do not have any relevant effect on the service life and can therefore be neglected.

The contact factor f_c refers to applications in which several sliders pass the same rail section. If two or more sliders move over the same point of a rail, the contact factor according to table 80 to be taken into account in the formula for calculation of the service life.

Number of sliders	1	2	3	4
f_c	1	0.8	0.7	0.63

Tab. 80

The application coefficient f_i takes into account the operational conditions in the service life calculation. It has a similar significance to the safety factor S_0 in the static load test. It is calculated as described in the following table:

f_i	
Neither shocks nor vibrations, smooth and low-frequency direction change; clean operating conditions; low speeds (<1 m/s)	1 - 1.5
Slight vibrations, average speeds (1 - 2.5 m/s) and average frequency of direction change	1.5 - 2
Shocks and vibrations, high speeds (> 2.5 m/s) and high-frequency direction change; extreme dirt contamination	2 - 3.5

Tab. 81

The stroke factor f_h takes into account the higher load of the raceways and rollers during short strokes on the same total length of run. The corresponding values are taken from the following graph (for strokes longer than 1 m, $f_h = 1$):



Fig. 195

Stand 11.2020 / Edition 02.2020

Sämtliche Informationen und Daten basieren auf unseren aktuellen Kenntnissen wie auch Erfahrungen und befreien den Verarbeiter/Anwender nicht von eigenen umfassenden Prüfungen. Eine rechtlich verbindliche Zusicherung, auch im Hinblick auf Schutzrechte Dritter, ist damit nicht gegeben. Der Verkauf unserer Leistungen und Produkte unterliegt unseren Verkaufs- und Lieferbedingungen. Alle Angaben und Spezifikationen in diesem Katalog sind ohne Gewähr, (technische) Änderungen sowie Irrtum vorbehalten.

All information and data are based on our current knowledge as well as our experience and do not relieve processors/users of their own comprehensive tests. A legally binding assurance event with respect to third parties has not been achieved at present. The sale of our products and services is subject to our sales- and shipment policies. All information and specifications in this catalogue are without any guarantee, (technical) changes and errors excepted.



HA-CO GmbH
Johann-Roithner-Straße 131
A-4050 Traun
Phone +43 7229 23844
info@ha-co.at
www.ha-co.at



HA-CO Motion AG
Lidwil 10
CH-8852 Altendorf
Phone +41 55 225 40 50
info@ha-co.ch
www.ha-co.ch



HA-CO Carbon GmbH
Albert-Einstein-Straße 1
D-86757 Wallerstein
Phone +49 9081 8050740
info@ha-co.de
www.ha-co.de



HA-CO GmbH
Daimlerring 10
D-63839 Kleinwallstadt
Phone +49 6022 655810
info@ha-co.eu
www.ha-co.eu

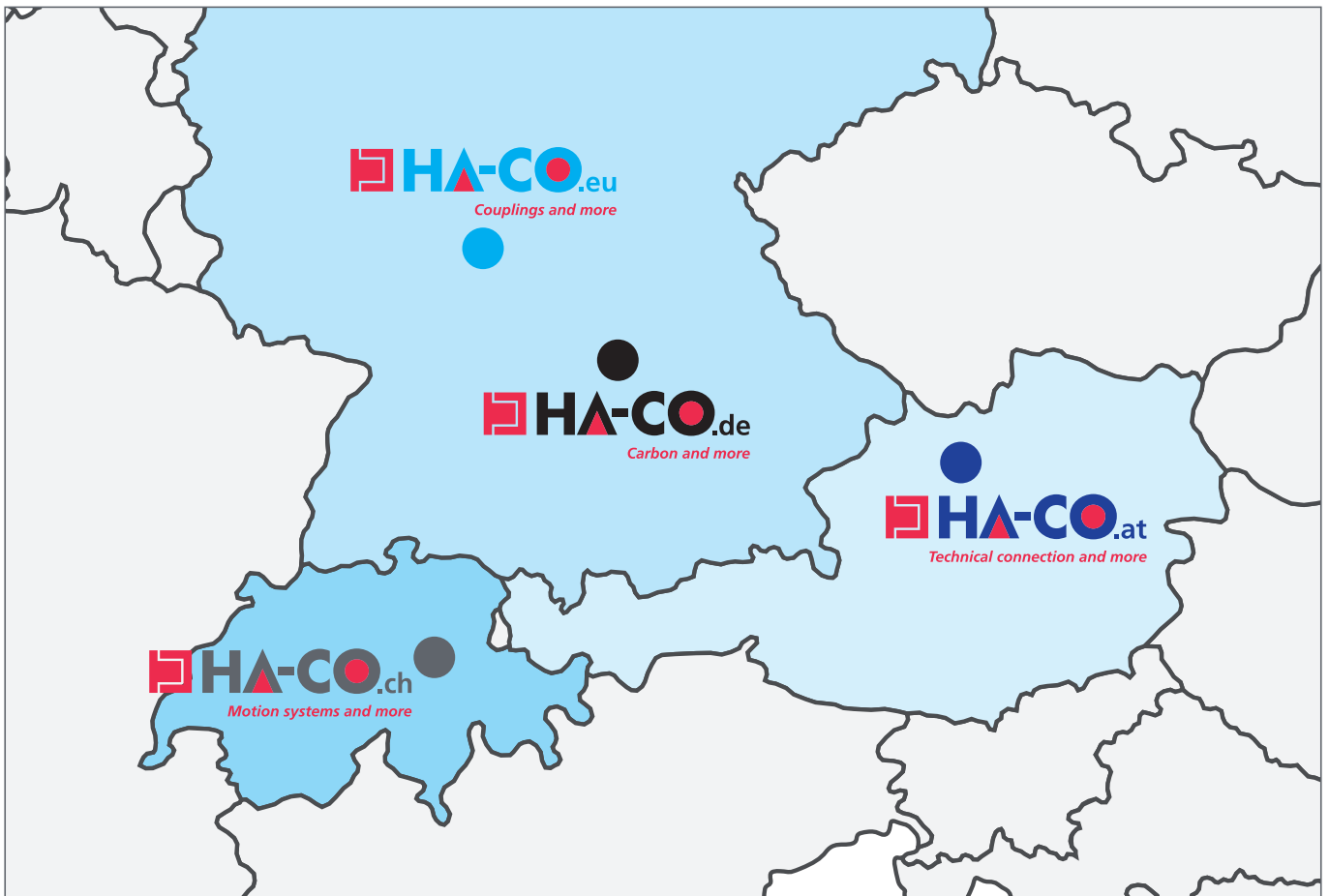

**Profitieren Sie von den Synergien
unserer Gruppe.**

**HA-CO.group
Technik vom Spezialisten –
fragen Sie uns an!**

**Profitez des synergies
de notre groupe**

**HA-CO.group
La technologie du spécialiste –
demandez-nous!**